

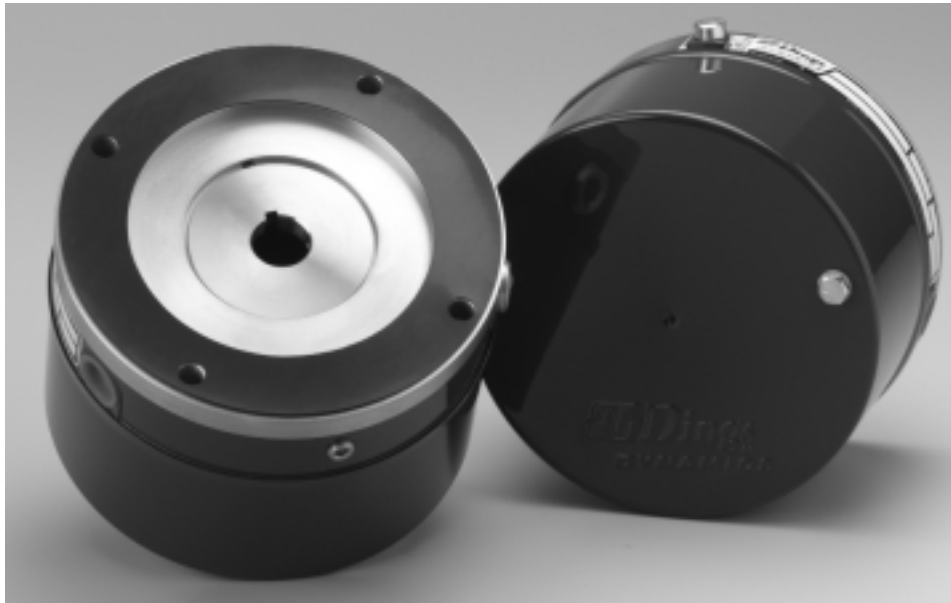

60 Series End-mount Brake Instructions Enclosed WPDT Housing with Deep Drawn Cover

Read carefully before attempting to assemble, install, operate or maintain the product described. Protect yourself and others by observing all safety information. Failure to comply with instructions could result in personal injury and/or property damage! Retain instructions for future reference. When unpacking the brake, inspect it carefully for damage that may have occurred during transit.



DESCRIPTION

These magnetic disc brakes mount directly onto NEMA 56C, 143TC, and 145TC frame motors, on the end opposite the drive shaft. The brake is direct acting, electro-magnetically released, and spring set. It uses rotating friction and stationary disc contact to supply positive braking action. It retains quick release and setting capabilities at all times.

Model 6-60000-545 is designed to mount directly onto C-face motors where a gasket between the brake and motor will prevent liquid media from entering the brake.

Model 6-60000-535 is for TEFC motors or foot mount applications. The hub seal prevents liquid media from entering the brake through openings in the motor fan cover or foot mounting bracket.

WARNING: Do not install or use these brakes in an explosive atmosphere.

SPECIFICATIONS

Torque: 1-1/2 through 20 lb. ft.

NEMA Motor Frame Sizes: 56C, 143TC and 145TC.

Enclosure: Aluminum, with steel cover.

Voltage: All NEMA single phase voltages and frequencies are standard. Others optional.

Duty: Rated for continuous duty.

Mounting: Direct to NEMA C face. Horizontal or vertical position with slight modifications.

Maximum Ambient Temperature: 40°C.

Maximum Input Speed: 3600 RPM.

G060969

DIMENSIONS

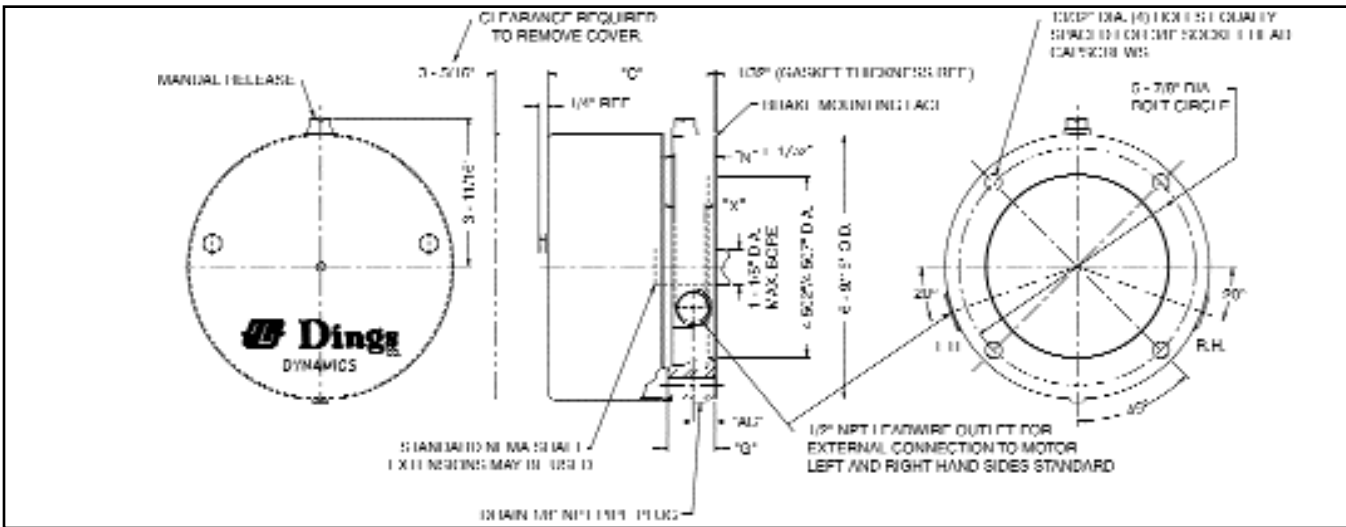

Figure 1

Model Number	Number of Rotating Discs	Torque Lb. Ft.	* Thermal Capacity HPS/MIN.	Inertia of Rotating Parts Lb. Ft. ²	Dimensions				
					X	G	AC	C	N _{±1/32}
6-61001-545	1	1.5	6	.006	.875	1.19	.585	4.13	1.156
6-61003-545	1	3	6	.006	.875	1.19	.585	4.13	1.156
6-62006-545	2	6	6	.010	.875	1.19	.585	4.13	1.156
6-62010-545	2	10	6	.010	.875	1.19	.585	4.13	1.156
6-63015-545	3	15	6	.015	1.187	1.56	.873	4.50	1.468
6-63020-545	3	20	6	.015	1.187	1.56	.873	4.50	1.468

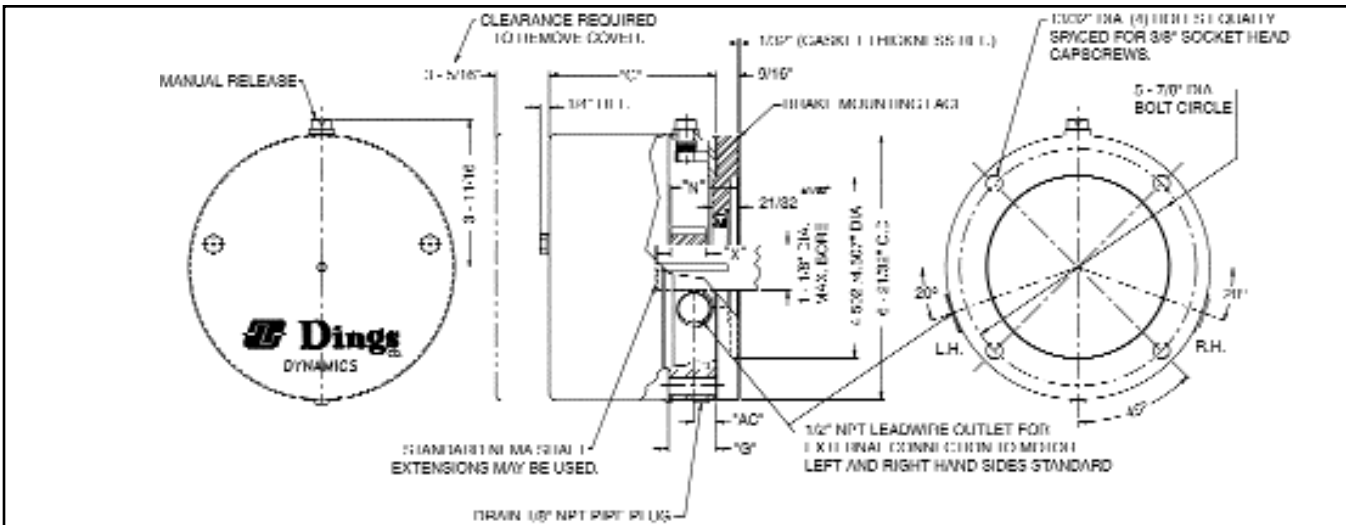

Figure 2

Model Number	Number of Rotating Discs	Torque Lb. Ft.	* Thermal Capacity HPS/MIN.	Inertia of Rotating Parts Lb. Ft. ²	Dimensions				
					X	G	AC	C	N _{±1/32}
6-61001-535	1	1.5	6	.006	.875	1.19	.585	4.13	1.687
6-61003-535	1	3	6	.006	.875	1.19	.585	4.13	1.687
6-62006-535	2	6	6	.010	.875	1.19	.585	4.13	1.687
6-62010-535	2	10	6	.010	.875	1.19	.585	4.13	1.687
6-63015-535	3	15	6	.015	1.187	1.56	.873	4.50	2.000
6-63020-535	3	20	6	.015	1.187	1.56	.873	4.50	2.000

*Thermal capacity (HPS/MIN.) was determined under the following test conditions:

- a) Room temperature 72°F.
- b) Stopping time of one second or less.
- c) Brake mounted in a horizontal position.
- d) Equal on and off times.
- e) 1800 RPM.
- f) Coil energized with 110% of rated voltage.

INSTALLATION

CAUTION: To preserve pre-alignment of rotating discs for ease of installation, do not operate manual release or energize brake coil before installation.

NOTE: The brakes are designed for horizontal mounting. Modification is required for vertical mounting. Brakes that are modified will have a prefix on the model number of VO (Vertical Over) or VU (Vertical Under).

Mounting Hub on Motor Shaft

For Model 6-60000-545:

Refer to Figure 3.

1. Place rotating disc hub, with key, onto motor shaft with part number facing away from motor. Measure from motor face as shown.
2. Tighten both setscrews to 8 - 10 lb. ft. torque.

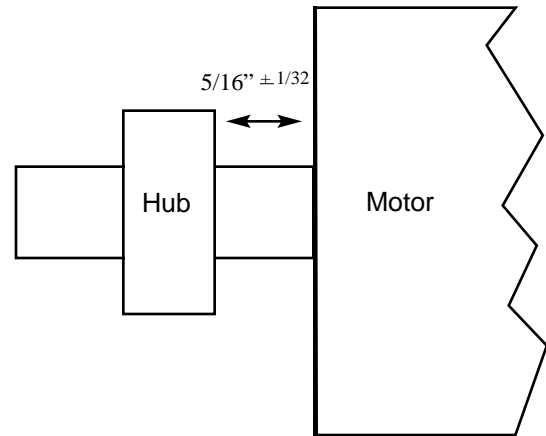

Figure 3

For Model 6-60000-535:

Refer to Figure 4.

1. Remove rubber v-ring from v-ring hub assembly.
2. Place v-ring hub assembly onto motor shaft, with part number facing away from motor. Measure from motor face as shown.
NOTE: If motor shaft keyway extends into v-ring area, install a key long enough to engage v-ring hub assembly and rotating disc hub. See step (3) before tightening setscrews. Tighten both setscrews to 35 lb. in. torque.
3. Place "RTV" sealant in small amounts to fill crevices only. Attention should be paid to the areas around and between the v-ring hub assembly, reference the .040" x 45° chamfer, motor shaft, hub keyway and motor shaft keyway. Use Dow Corning #739 RTV only; other types may form acetic acid during curing if subjected to water or high humidity. This will cause premature failure of zinc plated parts.

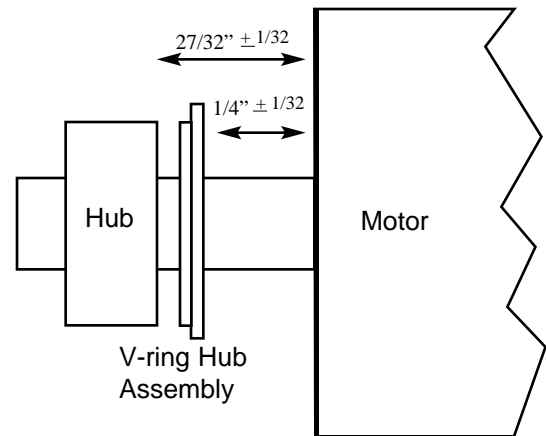

Figure 4

CAUTION: If this procedure is bypassed, liquid media may seep into the brake.

4. Replace v-ring onto v-ring hub assembly. Apply a small amount of grease to the lip of the v-ring.
5. Place rotating disc hub with key onto motor shaft with part number facing away from motor. Measure from brake mounting face as shown. Tighten both setscrews to 8 - 10 lb. ft. torque.

Placing Brake on Motor Shaft

1. Remove cover. Place gasket on the motor mounting face. Position brake over hub on shaft, aligning hub splines with rotating friction disc splines. Drain plug to face down on horizontal models.

NOTE: For model 6-60000-535 a second gasket is positioned between the bracket and adapter bracket. If gasket does not make contact around the mounting face completely (360°), remove gasket and place RTV sealant around the mounting bolt holes to approximately 1" dia. Use Dow Corning #739 RTV only; other types may form acetic acid during curing if subjected to water or high humidity. This will cause premature failure of zinc plated parts.

If tapped holes in motor for mounting bolts are not totally enclosed, place RTV sealant around threads before bolting brake to motor. Use Dow Corning #739 RTV only.

If water can accumulate in the cavity between the v-ring hub assembly and fan guard or other unsealed mounting face to the height of the v-ring seal, drill a hole in the fan guard or other equipment so the water drains out.

2. Tighten mounting bolts to 25 lb. ft. torque.
3. Connect coil leads as outlined under "Connection of Coil Leads" and Fig. 3.
4. Let RTV #739 cure 24 hours before replacing cover.
5. Replace cover. Tighten cover screws to 5 lb. ft. torque.

Connection of Coil Leads

After securing the brake to the motor, connect coil leads for proper voltage per wiring diagram (Fig. 5 shows dual voltage coil). Incorrect connection can result in brake failure.

CAUTION: The voltage supplied to the coil must match the voltage that the coils are connected for, or the coils will burn out.

Single voltage coil:

Connect brake coil leads to any two line leads (single or three phase) of same voltage and frequency as brake.

Dual voltage coil:

Connect leads 2 and 4 to any two motor line leads (single or three phase) of same voltage as brake. Connect leads 1 and 3 as shown for voltage desired. Brake must be energized with motor.

OPERATION

These brakes are spring set devices with an electrical (magnet) release. They contain a rotating friction disc that is driven by a hub mounted on the motor shaft. When energized, the magnet compresses the torque springs, removing the force pressing the stationary disc and friction disc together. This permits free rotation of the shaft.

WARNING: Observe proper safety precautions in applications where a brake failure would allow the load to move in such a manner as to injure personnel. KEEP PERSONNEL AWAY FROM LOAD AREAS.

If brake torque rating is higher than motor full-load torque rating, use brake rating rather than motor rating when selecting other drive components.

Take the following precautions when operating the brake:

1. Do not operate the brake at higher than nominal static torque capacity.
2. For applications with high inertia-type loads or rapid cycling, the thermal capacity of the brake must be considered.
3. High start-stop rates may damage motor. Consult motor manufacturer if high cycling rates are expected.
4. Be sure power supply conforms to electrical rating of brake.

Manual Release

The brake is equipped with a manual release. Turn the release knob clockwise to stop position to release the brake. The brake will remain released until the release knob is turned counterclockwise (approx. 65°) or until the brake coil is energized, automatically resetting the brake.

Wiring Diagrams

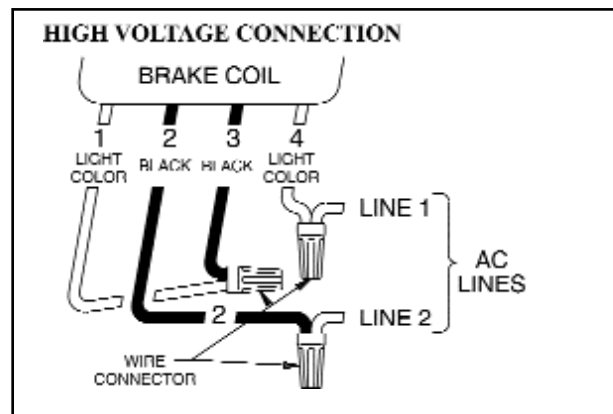
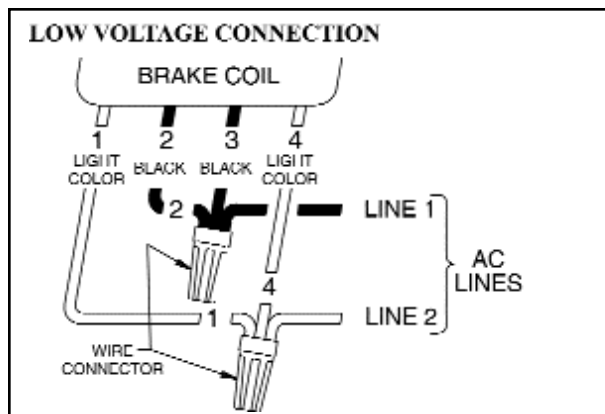

MAINTENANCE

Caution: Before attempting to service or remove any components, make certain that the power is disconnected and that the load is completely removed, secured or blocked to prevent injury or property damage.

Wear Adjustment

Caution: Load to be removed or blocked. Brake may be inoperative during this procedure.

Before air gap "A" reaches .100", adjustment is required. Any delay in adjusting the magnet air gap will result in eventual loss of torque.

Refer to Figure 6.

1. Remove cover to expose square head wear adjusting screws (15H) and expose magnet air gap "A."
2. Measure air gap "A" using 3/8" to 1/2" wide feeler gauge. (Measure at center of magnet.) Air gap must be the same on both sides of magnet.
3. Turn two square head adjusting screws (15H) until air gap "A" measures:
 - .045/.050 for 1 disc models
 - .050/.055 for 2 disc models
 - .060/.065 for 3 disc models
4. Replace cover, sealing washers and cover screws. Tighten to 5 lb. ft. torque.

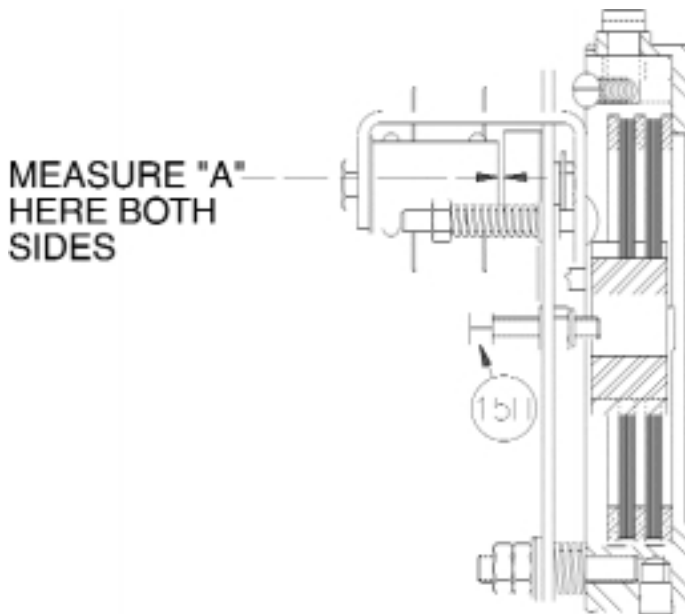

Figure 6

Torque Adjustment

Caution: Load to be removed or blocked. Brake may be inoperative during this procedure.

The magnetic disc brake is factory set for rated static torque. The brake can be adjusted to reduce torque which increases stopping time. Do not attempt to adjust brake for higher torque, as this will cause premature coil burnout.

Refer to Figure 7.

1. To adjust, remove cover to expose torque locknuts (15T), which are above torque springs (15S).
2. To increase stopping time and reduce torque, turn both torque locknuts counterclockwise, increasing spring length. Each full turn reduces torque 7% to 10% depending on the model.

NOTE: Maximum spring length is 1.2". At maximum length reduced torque will be:

Rated Torque	Reduced Torque
1.5 lb. ft.	1.0 lb. ft.
3 lb. ft.	2 lb. ft.
6 lb. ft.	4 lb. ft.
10 lb. ft.	7 lb. ft.
15 lb. ft.	10 lb. ft.
20 lb. ft.	13 lb. ft.

3. Replace cover, sealing washers and cover screws. Tighten to 5 lb. ft. torque.

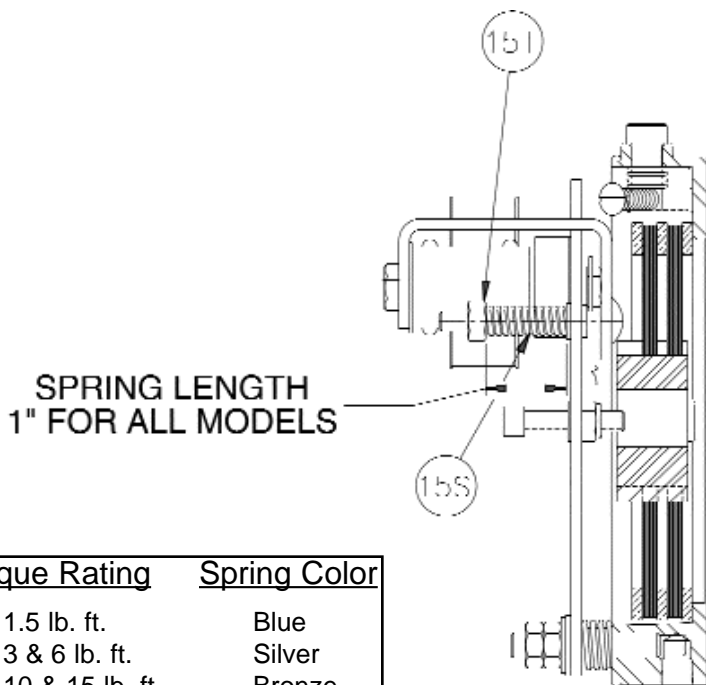

Figure 7

Torque Rating	Spring Color
1.5 lb. ft.	Blue
3 & 6 lb. ft.	Silver
10 & 15 lb. ft.	Bronze
20 lb. ft.	Green

Friction Disc Replacement

Caution: Load to be removed or blocked. Brake will be inoperative during this procedure.

When total wear on a rotating friction disc reaches 1/16", replace disc. If brake model number has a prefix VO or VU, see page 8. Numbers in parentheses refer to parts illustrated in Figure 12.

1. **Removing operator assembly**
 - a. Disconnect power.
 - b. Remove cover.
 - c. Remove operator assembly (15) by removing screws (16), pivot stud (10), washer (18), bushing (17), and compression spring (11). NOTE: Item (10) has a hex socket in end of stud for removal. Do not loosen nuts (19) on pivot stud (10), or "Pivot Stud Adjustment" (on page 7) to quiet the magnet will have to be made again.
2. **Replacing the friction disc**

Remove worn rotating discs (13) and stationary discs (12). Replace worn discs and install new discs in the same order. Install stabilizer clip (14), if furnished, on rotating discs prior to installing.
3. **Re-assembly of operator assembly (15)**
 - a. Turn two screws (15H) counterclockwise five turns. Place operator assembly onto brake bracket (2) and install two screws (16). Replace compression spring (11), bushing (17), washer (18), and pivot stud (10) which has the two nuts (19) in place. Tighten firmly.
 - b. Readjust magnet air gap "A" as described under "Wear Adjustment" on page 5.
 - c. Check manual release operation before completing installation. Adjust per "Manual Release Adjustment" on page 7 if required.
4. **Completing installation**

Replace cover. Tighten cover screws to 5 lb. ft. torque. Reconnect power.

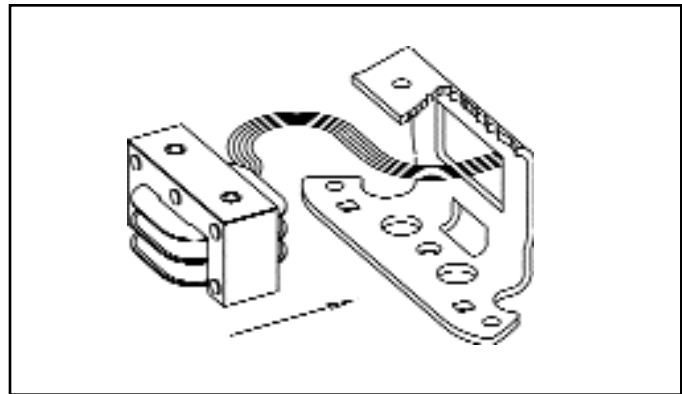

Figure 8

Magnet Assembly Replacement

Caution: Load to be removed or blocked. Brake will be inoperative during this procedure.

1. Disconnect power supply.
2. Remove cover.
3. Remove two capscrews (15D), magnet assembly (15A) and shock mount (15B).
4. Replace with new magnet assembly (15A), making sure shock mount (15B) is in place. Feed coil lead wires through hole in back of bracket (15C) as shown in Fig. 8. Tighten mounting screws (15D) with 55-60 lb. in. torque.
5. Place coil lead wires around mounting bracket (15C) to the same side as the wire outlet position. Connect leads wires per "Connection of Coil Leads" and Fig. 5.
6. Set air gap "A" as described under "Wear Adjustment" on page 5.
7. Energize coil. Magnet should be quiet; if not, refer to "Pivot Stud Adjustment" on page 7.
8. Check manual release. If it does not operate properly, adjust as outlined under "Manual Release Adjustment" on page 8.
9. Replace cover. Tighten cover screws to 5 lb. ft. torque. Reconnect power.

Armature Plate Assembly Replacement

Caution: Load to be removed or blocked. Brake will be inoperative during this procedure.

If you replace the magnet assembly, it may be necessary to replace the armature plate assembly. If it is badly deformed, it will be difficult to make the magnet quiet.

1. To replace, remove operator assembly (15) from brake. See "Friction Disc Replacement Steps 1-3" on page 6.
2. Remove nuts (15T), springs (15S), and carriage bolts (15R). This will allow the armature plate assembly (15E) to be removed from magnet bracket.
2. Reassemble new armature plate assembly to magnet bracket (15C) using items (15R), (15S) and (15T). Reassemble operator assembly to brake bracket. Set magnet air gap "A" and set torque springs (15S) to 1" as shown in Fig. 6 and 7.

Pivot Stud Adjustment

Caution: Load to be removed or blocked. Brake will be inoperative during this procedure.

This adjustment is made at the factory and may be required when replacing the magnet assembly or the armature plate assembly.

The purpose is to regulate the height of the armature plate so that when the magnet is energized, the armature is parallel with it. This is required so that the magnet will be quiet.

NOTE: Cover must be removed to make this adjustment.

1. To adjust: Hold nut (19) which is adjacent to washer (18) and loosen the other nut (19) and remove it from the stud.
2. Energize the magnet and turn remaining nut (19) counterclockwise slowly until the magnet becomes noisy. Turn magnet on and off several times until you find the position where the magnet first becomes quiet. At this point turn nut (19) 1/3 turn (two flats) in a clockwise position. Hold nut in this position and turn magnet on and off to make sure the magnet does not become noisy.
3. Holding this nut in place, screw on other nut and tighten it against the nut you are holding. Tighten firmly.
4. Operate the manual release. If the release does not operate properly, see "Manual Release Adjustment."

Manual Release Adjustment

Caution: Load to be removed or blocked. Brake will be inoperative during this procedure.

The manual release (3) may require adjustment after replacing the operator assembly (15), magnet (15A), or armature plate assembly (15E). It also may be required if adjustments are made on the pivot stud nuts (19).

The release is working properly if:

- a) You turn release knob clockwise to stop and the brake is released;
- b) The release knob returns to its normal position automatically when power is applied to the magnet.

NOTE: Cover must be removed to make this adjustment.

1. To adjust: Set air gap "A" as described under "Wear Adjustment" on page 5.
2. If the brake does not release, turn adjusting screw (5) counterclockwise 1/4 turn and try again.
3. If the release knob (3) does not return to its normal position automatically, turn screw (5) clockwise 1/4 turn and try again.

NOTE: You may have to repeat Steps 2 or 3 to get the release to operate properly.

It is important that the release knob returns to its normal position automatically when power is applied to the magnet.

Manual Release Assembly

Refer to Fig. 9.

1. Place a small amount of high temperature Neverseize grease around o-ring (24) located on release knob (3) and in release hole located at the top of bracket (2).
2. Place shaft of release knob (3) through hole in bracket (2). Slide return spring (4) over shaft; straight leg of spring should enter shaft first with leg in the position shown.
3. Slip spring (6) over screw (5) and install in tapped hole in release shaft. Screw in until it stops. Make sure spring (4) is not caught under spring (6).
4. Engage bent end of spring (4) over spring (6) as shown. Pull it over with a needle nose pliers or screwdriver.
5. Adjust release per "Manual Release Adjustment" section.

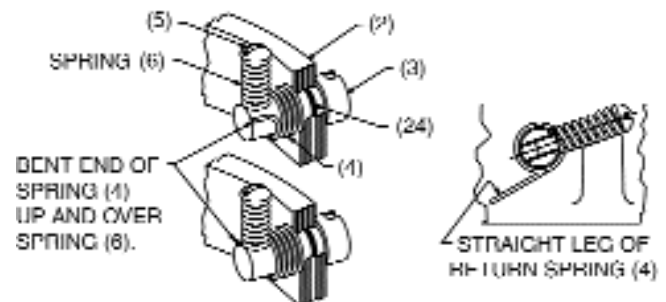

Figure 9

VERTICAL MOUNTING

Installation and adjustment of the vertically mounted brake is the same as on the standard model.

Friction Disc Replacement

When replacing friction discs, follow procedure outlined on page 6, with this addition:

Care must be taken to insure proper insertion of disc separating springs. Springs are color coded for easy identification, and reference is made to spring color (see Figs. 10 and 11). Since the installation order of the disc springs is dependent on brake mounting position (above or below motor), it is important to consult the correct diagram for spring location.

Item No.	Description	Part No.	Qty. of Parts (determined by no. of rotating discs)		
			1	2	3
1	Spring (silver)	G060350-001	2	2	2
2	Spring (black)	G060350-002	-	2	2
3	Spring (bronze)	G060350-003	-	-	2
4	Roll pin-1/8" dia. x 5/8" lg.	W005003-071	2	-	-
5	Roll pin-1/8" dia. x 1" lg.	W005003-077	-	2	-
6	Roll pin-1/8" dia. x 1-3/8" lg.	W005003-080	-	-	2
7	Stationary disc	H060203-003	1	1	1

Figure 10 Parts for Vertical Mounting

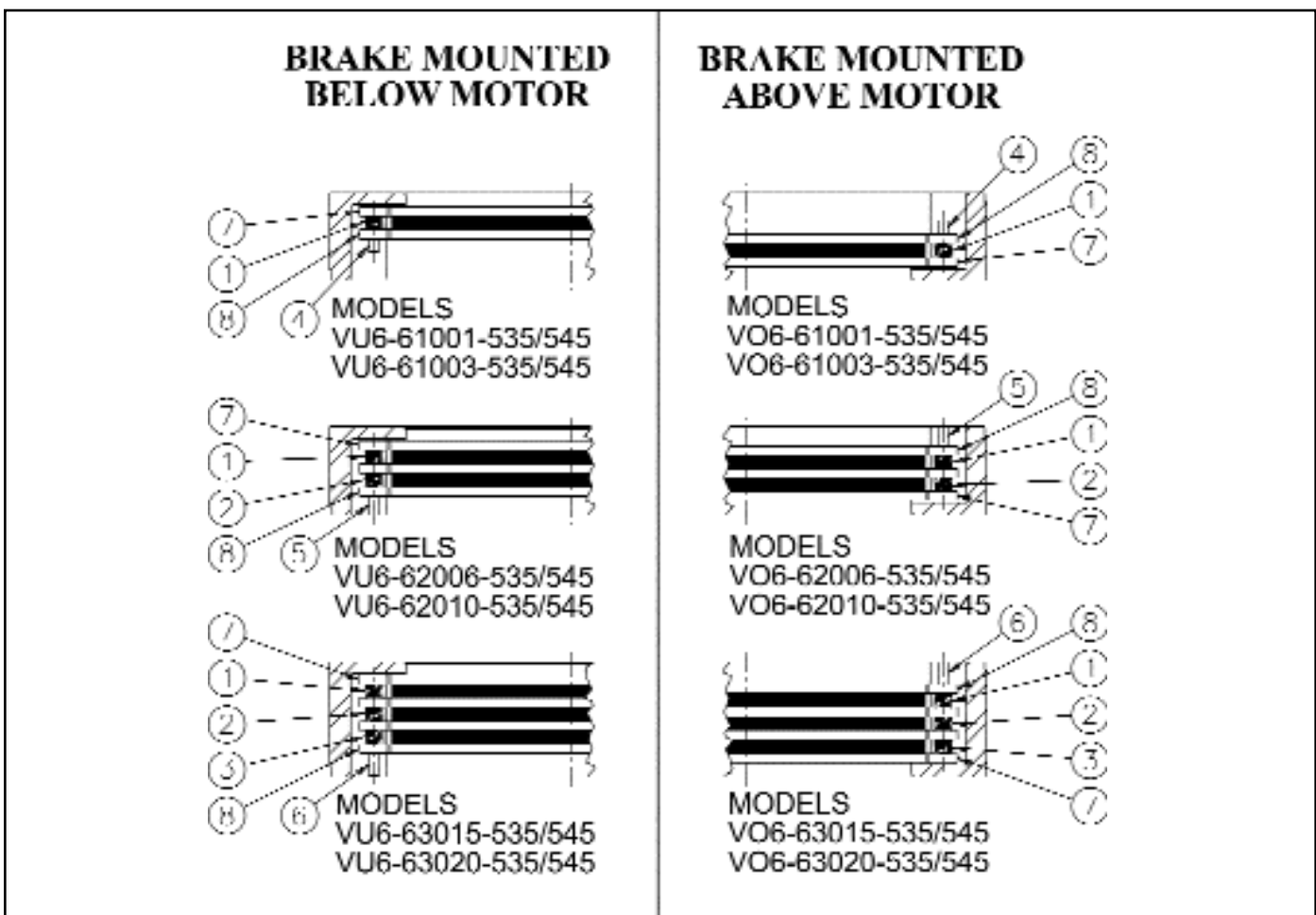

Figure 11

WARNING:

Brake performance and features must be carefully matched to the requirements of the application.

Consideration must be given to torque requirements, especially where an overhauling condition exists, as well as thermal capacity, ambient temperature, atmospheric explosion hazards, type of enclosure and any other unusual conditions.

Improper selection and installation of a brake and/or lack of maintenance may cause brake failure that could result in damage to property and/or injury to personnel.

If injury to personnel could be caused by brake failure, additional means must be provided to insure safety of personnel.

GENERAL SAFETY INFORMATION

NOTE: These brakes are not intended for accurate positioning applications. They are designed for applications that require rapid stopping and holding power, such as on conveyors, door openers, etc.

1. For applications with high inertia-type loads or rapid cycling, the thermal capacity of the brake must be considered.
2. Observe all local electrical and safety codes, as well as the National Electrical Code (NEC) and the Occupational Safety and Health Act (OSHA).
3. Brake motors and brake gearmotors must be securely and adequately grounded. This can be accomplished by wiring with a grounded metal-clad raceway system, by using a separate ground wire connected to the bare metal of the motor frame, or other suitable means. Refer to NEC Article 250 (Grounding) for additional information. All wiring should be done by a qualified electrician.
4. Always disconnect power before working on or near a brake motor, a brake gearmotor, or its connected load. If the power disconnect point is out of sight, lock it in the open position and tag it to prevent unexpected application of power.
5. When working on the brake, be sure the load is completely removed, secured or blocked to prevent injury or property damage.
6. Provide guarding for all moving parts.
7. Be careful when touching the exterior of an operating motor, gearmotor or brake. It may be hot enough to cause injury or to be painful. This condition is normal for modern motors, which operate at higher temperatures when running at rated load and voltage.
8. Protect all electrical lead wires and power cables against contact with sharp objects or moving parts.
9. Do not kink electrical lead wires and power cables, and never allow them to touch oil, grease, hot surfaces or chemicals.

WARRANTY

Seller warrants products manufactured by it and supplied hereunder to be free from defects in materials and workmanship under normal use and proper maintenance for a period of twelve months from date of shipment. If within such period any such products shall be proved to Seller's reasonable satisfaction to be defective, such products shall be repaired or replaced at Seller's option. Seller's obligation and Buyer's exclusive remedy hereunder shall be limited to such repair and replacement and shall be conditioned upon Seller's receiving written notice of any alleged defect no later than 10 days after its discovery within the warranty period and, at Seller's option, the return of such products to Seller, f.o.b. its factory, when such return is feasible. Seller reserves the right to satisfy its warranty obligation in full by reimbursing Buyer for all payments it makes hereunder, and Buyer shall thereupon return the products to Seller. Seller shall have the right to remedy such defects. Seller makes no warranty with respect to wear or use items such as belts, chains, sprockets, discs and coils, all of which are sold strictly AS IS.

The foregoing warranties are exclusive and in lieu of all other express and implied warranties (except of title) including but not limited to implied warranties of merchantability, fitness for a particular purpose, performance, or otherwise, and in no event shall the Seller be liable for claims (based upon breach of express or implied warranty, negligence, product liability, or otherwise) for any other damages, whether direct, immediate, incidental, foreseeable, consequential, or special.

REPLACEMENT PARTS LIST

Item No.	Description	With Hub Seal		Without Hub Seal	
		Qty	6-60000-535	6-60000-545	Qty
1	Splined hub	1	K060107-*		1
2	Bracket 1 & 2 disc models	1	K060556-001		1
	3 disc models	1	K060557-001		1
3	Release knob	1	G060848-001		1
4	Release return spring	1	G060881-001		1
5	Release adjustment screw	1	W001002-056C		1
6	Release adjustment spring	1	G060795-001		1
7	Nameplate	1	G060970-001		1
8	Pipe plug 1/2" NPT	1	W010002-004C		1
9	Cover stud	2	G060902-001		2
10	Pivot stud	1	W002005-303A		1
11	Compression spring, 1.5 lb. ft. through 15 lb. ft.	1	G060821-001		1
	Compression spring, 20 lb. ft.	1	G060852-001		1
12	Stationary disc	**	H060147-001		**
13	Splined rotating friction disc	**	H060157-003		**
14	Stabilizer clip for rotating friction disc	**	H060466-001		**
15	Operator assembly (not shown as assembly)	1	K060476-*		1
15A	Magnet assembly	1	*		1
15B	Magnet shock mount	1	G060813-001		1
15C	Magnet mounting bracket	1	H060544-001		1
15D	Hex head capscrew 1/4-20 UNC x 1/2 lg.	2	W001008-001E		2
15E	Armature assembly (not shown) (Includes items 15F through 15Q)	1	H060541-*		1
15F	Armature plate	1	Armature assembly (15E) sold as preassembled kit only. Individual items listed for reference only and are not available for individual purchase.		1
15G	Nyliner bushing	2			2
15H	Wear adjustment screw sq. hd. 1/4-20 UNCx1-1/2 lg.	2			2
15I	Roll pin 5/32" dia. x 3/8" lg.	1			1
15J	Armature lamination assembly	1			1
15K	Armature shock mount	1			1
15L	Armature spacer	2			2
15M	Hex hd. capscrew 1/4-20 UNC x 5/8 lg. Grade 5	2			2
15N	Locking plate	1			1
15P	Split spring lockwasher #8	1			1
15Q	Soc. hd. capscrew #8-32 UNC x 1/4 lg.	1			1

Item No.	Description	With Hub Seal		Without Hub Seal	
		Qty	6-60000-535	6-60000-545	Qty
15R	Carriage bolts 1/4-20 UNC	2	G060803-001		2
15S	Torque spring (blue) 1.5 lb. ft. models	2	G060791-001		2
	Torque spring (silver) 3 & 6 lb. ft. models	2	G060792-001		2
	Torque spring (bronze) 10 & 15 lb. ft. models	2	G060793-001		2
	Torque spring (green) 20 lb. ft. models	2	G060794-001		2
15T	Lock nut 1/4-20 UNC	2	W003013-001		2
16	Hex hd. capscrew 1/4-20 x 1/2 lg.	4	W001008-001E		4
17	Nylon bushing	1	G060820-001		1
18	Plain brass washer	1	W004003-024		1
19	Hex nut 5/16-18 UNC	2	W003002-002E		2
20	Cover	1	H060607-002		1
21	Instruction label (not shown)	1	K060553-001 K060552-001		1
22	Nylon washer	2	W0040015-001		2
23	Cover seal	1	G060947-001		1
24	O-ring for release	1	W006001-025		1
25	Release label	1	G060859-001		1
26	Gasket, mounting face	2	H060344-003		1
27	Adapter bracket	1	H060604-001		—
28	V-ring hub seal assembly (Includes items 29 through 31)	1	H060555-***		—
29	V-ring hub assembly (includes item 30)	1	G060814-***		—
30	Setscrew #10-32 UNF x 1/4 lg.	2	W002001-061		—
31	V-ring (V-50A)	1	W011008-002		—
32	Pipe plug 1/8 NPT	1	W010002-001C		1

* Part number is determined by one or more of the following: model number, voltage, or motor shaft diameter and keyway sizes.

** Number of rotating discs, stationary discs, and rotating friction disc stabilizer clips is shown in the brake model number. Example: -62006- has two rotating discs, two stationary discs, and two stabilizer clips (when used).

*** For use with Model 6-60000-535 only. Items 28 and 29 require motor shaft diameter and keyway size.

TROUBLESHOOTING CHART

SYMPTOM	POSSIBLE CAUSE	CORRECTIVE ACTION
Brake does not release	<ol style="list-style-type: none"> 1. Broken or damaged parts. 2. Wrong voltage. 3. Burned out coil. 4. Incorrect wiring connections or broken wires. 	<ol style="list-style-type: none"> 1. Replace. 2. Check for correct voltage. Voltage must correspond to that listed on brake nameplate. If the voltage is more than 10% below the nameplate voltage, the magnet may not pull in. 3. Replace magnet assembly. 4. Find the connection or wiring fault. Correct or repair as required.
Brake does not stop properly	<ol style="list-style-type: none"> 1. Broken or damaged parts. 2. Worn friction disc. 3. Hub positioned incorrectly. 4. Brake is manually released. 	<ol style="list-style-type: none"> 1. Replace. 2. Replace disc if worn to 1/8" thickness. If disc replacement is not required, adjust air gap. (Refer to "Wear Adjustment" section.) 3. Relocated hub and key, if required. (Refer to "Installation" section.) 4. Determine if manual release is in normal position.
Brake chatters or hums	<ol style="list-style-type: none"> 1. Dirty magnet faces. 2. Magnet faces are not parallel in closed position. 3. Loose or broken shading coil. 4. Wrong voltage supply. 	<ol style="list-style-type: none"> 1. To remove dirt, insert a clean sheet of paper between faces and energize brake. Move paper around between faces to dislodge dirt, then remove paper. 2. See "Pivot Stud Adjustment" section. 3. Replace magnet assembly. 4. Check for low voltage.
Manual release does not work	<ol style="list-style-type: none"> 1. Broken or damaged parts. 2. Improper setting. 	<ol style="list-style-type: none"> 1. Replace. 2. See "Manual Release Adjustment" section.

ORDERING INFORMATION

Replacement parts can be purchased from your local distributor or from the Dings Co. To obtain the name of your local distributor, call us or visit our website at www.dingsco.com.

For replacement parts, please furnish this data with your order:

- Brake model number
- Part number and description (refer to parts list)
- If ordering a hub, specify bore diameter and keyway dimensions
- If ordering electrical parts, specify voltage and frequency

For a replacement brake, please furnish this data with your order:

- Brake model number
- Voltage and frequency
- Hub bore and keyway dimensions
- Mounting - horizontal or vertical. If vertical, specify whether above or below motor. If brake includes foot mounting bracket or adapter, specify.

