

Elastomer-in-Shear Type Couplings

The simple design of the S-Flex coupling ensures ease of assembly and reliable performance. No special tools are needed for installation or removal. S-Flex couplings can be used in a wide variety of applications.

Features and Benefits

- n Easy to Install.
- n Maintenance Free.
- n No Lubrication.
- n Dampens Vibration and Controls Shock.
- n Torsionally Soft.
- n Double Engagement.

The S-Flex coupling design is comprised of three parts. Two flanges with internal teeth engage an elastomeric flexible sleeve with external teeth. Each flange is attached to the respective shaft of the driver and driven and torque is transmitted across the flanges through the sleeve. Misalignment and torsional shock loads are absorbed by shear deflection in the sleeve. The shear characteristic of the S-Flex coupling is very well suited to absorb impact loads.

The S-Flex coupling from Lovejoy offers combinations of flanges and sleeves which can be assembled to suit your specific application. Thirteen sizes are available with torque capabilities that range from 60 in-lb to 72,480 in-lb.

The S-Flex flanges are offered in five models which are made from zinc die cast or cast iron. Sleeves are available in EPDM rubber, Neoprene, or Hytrel to address a wide variety of application requirements.

Flange Types:

- Type J — Zinc Die Cast and Cast Iron, Bore Range ... $\frac{3}{8}$ " — $1\frac{7}{16}$ "
- Type S — Cast Iron, Bore Range ... $\frac{1}{2}$ " — $5\frac{1}{2}$ "
- Type B — Cast Iron w/QD Bushing
- Type SC — Cast Iron Spacer
- Type T — Cast Iron w/Taper-lock bushing

Hubs for Type SC Spacer Coupling:

- Type H — Powdered Metal or Cast Iron, Standard Length
- Type HS — Powdered Metal or Cast Iron, Short Length

Sleeve Types:

- | | | |
|-------|------------|-----------------------------|
| JE – | (EPDM) | 1-piece solid |
| JES – | (EPDM) | 1-piece split |
| JN – | (Neoprene) | 1-piece solid |
| JNS – | (Neoprene) | 1-piece split |
| E – | (EPDM) | 2-piece with retaining ring |
| N – | (Neoprene) | 2-piece with retaining ring |
| H – | (Hytrel) | 1-piece |
| HS – | (Hytrel) | 2-piece split |

Protection from misalignment, shock, and vibration:

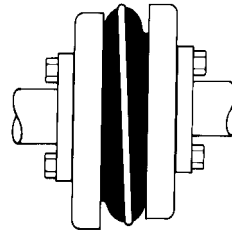

PARALLEL:

The S-Flex coupling accepts up to .062 in of parallel misalignment without wear. The flexible coupling sleeve minimizes the radial loads imposed on equipment bearings, a problem commonly associated with parallel misalignment.

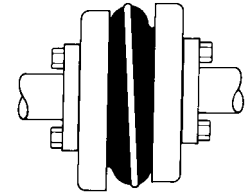

AXIAL:

The S-Flex couplings can be used in applications which require a limited amount of shaft end-float without transferring thrust loads to equipment bearings. Axial movement of approximately $\frac{1}{8}$ " accepted.

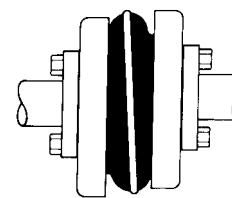

ANGULAR:

The flexing action of the elastomeric sleeve and the locking feature of the mating teeth allows the S-Flex coupling to effectively handle angular misalignment up to 1°.

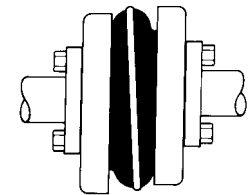

TORSIONAL:

S-Flex couplings effectively dampen torsional shock and vibration to protect connected equipment. The EPDM and Neoprene sleeves have torsional wind-up flexibility of 15° at their rated torque. Hytrel provides 7° wind-up.



WARNING

You must refer to page iv for Important Safety Instructions and Precautions for the selection and use of these products. Failure to follow the instructions and precautions can result in severe injury or death.

Elastomer Designs

Lovejoy offers flexible sleeves for S-Flex couplings in three designs: One-piece solid, one-piece split, and two-piece with retaining ring. The one-piece solid design provides a simple installation for most applications, and the split design provides solutions for applications with unique requirements where small shaft separations inhibit the installation of a one-piece sleeve.

In all designs, pre-molded teeth along the diameter of the sleeve engage with teeth of the coupling flanges. No clamps or screws are needed to connect the flanges with the flexible sleeve which securely lock together under torque for smooth transmission of power.

Torque is transmitted through shear loading of the sleeve. All three sleeve materials are highly elastic which permits the S-Flex coupling to protect connected equipment from harmful shock loading, vibration, and shaft misalignment.

Sleeve Types JE, JN, JES, JNS

These sleeves feature a one-piece design molded in EPDM & Neoprene rubber. In the case of JES & JNS Types, the one-piece design is split to provide for ease of installation and removal.

Sleeve Types E, N

These sleeves feature a two-piece design with retaining ring. The E Type is molded in EPDM rubber and the N Type is molded in Neoprene. The two-piece design is ideal for applications where there is difficulty in separating the shafts of the driver and driven.

Sleeve Types H, HS

These sleeves feature both a one-piece solid (H) and two-piece split (HS) design and are molded of Hytrel. The sleeves in Hytrel material are designed to transmit power for high torque applications. Because of the design and the properties of the Hytrel molded sleeve, the H and HS sleeves should not be used as direct replacements for EPDM or Neoprene sleeves, and can only be used with S, TF, or SC flanges.



Sleeve Materials

EPDM—Unless otherwise specified, S-Flex couplings are supplied with EPDM flexible sleeves. EPDM has good resistance to commonly used chemicals and is generally not affected by dirt or moisture. Color is black.

NEOPRENE²—Neoprene provides very good performance characteristics for most applications and offers a very good resistance to chemical and oil conditions. Color is black with a green dot.

HYTREL²—Hytrel is a polyester elastomer designed for high torque and high temperature applications and offers excellent resistance to chemical and oil conditions. Color is orange.

- Notes:**
1. See page ED-13 for sleeve chemical resistance chart.
 2. Hytrel is a registered trademarks of E.I. DuPont Nemours & Co.

S-Flex Coupling Selection Process

The selection process for determining the proper S-Flex coupling requires using the charts shown on the following pages. There are three components to be selected, two flanges and one sleeve.

Information necessary before a coupling can be selected:

- n HP and RPM of Driver or running torque
- n Shaft size of Driver and Driven equipment and corresponding keyways
- n Application or equipment description
- n Environmental conditions (i.e. extreme temperature, corrosive conditions, space limitations)

List of Charts provided for Selection:

Chart 1—Application Service Factors (pg. SF-5)

Chart 2—Sleeve Performance Data (pg. SF-6)

Chart 3—Coupling Nominal Rated Torque (pg. SF-6)

Formulas:

$$\text{Nominal Torque} = \text{in-lb} = \frac{(\text{HP} \times 63025)}{\text{RPM}}$$

$$\text{Nm} = \frac{(\text{KW} \times 9550)}{\text{RPM}}$$

$$\text{Design Torque} = \text{Nominal Torque} \times \text{Application Service Factor}$$

SF

Steps in Selecting a Coupling

Step 1: Determine the Nominal Torque in in-lb of your application by using the following formula:

$$\text{Nominal Torque} = \frac{(\text{HP} \times 63025)}{\text{RPM}}$$

Step 2: Using the Application Service Factor Chart 1 (pg. SF-5) select the service factor which best corresponds to your application.

Step 3: Calculate the Design Torque of your application by multiplying the Nominal Torque calculated in Step 1 by the Application Service Factor determined in Step 2.

$$\text{Design Torque} = \text{Nominal Torque} \times \text{Application Service Factor}$$

Step 4: Using the S-Flex Sleeve Performance Data Chart 2 (pg. SF-6) select the sleeve material which best corresponds to your application.

Step 5: Using the S-Flex Coupling Nominal Rated Torque Chart 3 (pg. SF-6) locate the appropriate sleeve material column for the sleeve selected in Step 4.

Step 6: Scan down this column to the first entry where the Torque Value in the column is greater than or equal to the Design Torque calculated in Step 3.

Refer to the maximum RPM value of the coupling size to ensure that the application requirements are met. If the maximum RPM value is less than the application requirement, S-Flex couplings are not recommended for the application.

Note: If Nominal Torque is less than $\frac{1}{4}$ of the coupling's nominal rated torque, misalignment capacities are reduced by $\frac{1}{2}$. Once torque value is located, refer to the corresponding coupling size in the first column of the Coupling Nominal Rated Torque Chart 3 (pg. SF-6).

Step 7: Compare the application driver/driven shaft sizes to the maximum bore size available on the coupling selected. If coupling max. bore is not large enough for the shaft diameter, select the next largest coupling that will accommodate the driver/driven shaft diameters.

Step 8: Using the Item Selection charts, find the appropriate Keyway and Bore size required and locate the Lovejoy Item (UPC) number.

Application Service Factors

Chart 1

	Service Factors				Service Factors				Service Factors		
	Electric Motor w/ Standard Torque	Electric Motor w/ High Torque	Turbines, Air & Hydraulic Motors		Electric Motor w/ Standard Torque	Electric Motor w/ High Torque	Turbines, Air & Hydraulic Motors		Electric Motor w/ Standard Torque	Electric Motor w/ High Torque	Turbines, Air & Hydraulic Motors
Agitators	1.25	1.50	1.00	Dough Mixer	1.50	2.00	1.25	Notching, Paper, Punch			
Band Resaw (lumber)	1.50	2.00	1.25	Draw Bench Conveyor & Main Drive	2.00	2.50	1.50	Printing	1.50	2.00	1.25
Barge Haul Puller	2.00	2.50	1.50	Dredges				Pug Mill	1.50	2.00	1.25
Barking (lumber)	2.00	2.50	1.50	Cable reef, Pumps	1.50	2.00	1.25	Pulp Grinder (paper)	2.00	2.50	1.50
Bar Screen (sewage)	2.00	2.50	1.50	Cutter head, Jig, &				Pulverizers			
Batches (textile)	1.25	1.50	1.00	Screen Drives	2.00	2.50	1.50	Hammermill—Light Duty,			
Beater and Pulper (paper)	1.50	2.00	1.25	Maneuvering & Utility				Roller	1.50	2.50	1.25
Bending Roll (metal)	1.50	2.00	1.25	Winch, Stacker	1.50	2.00	1.25	Hammermill—Heavy			
Bleacher (paper)	1.25	1.50	1.00	Dynamometer	1.25	1.50	1.00	Duty Hog	2.00	2.50	1.50
Blowers				Dryers (rotary)	1.50	2.00	1.25	Pumps			
Centrifugal, Vane	1.25	1.50	1.00	Edger (lumber)	2.00	2.50	1.50	Centrifugal, Axial	1.25	1.50	1.00
Lobe	1.50	2.00	1.25	Escalators	1.25	1.50	1.00	Gear, Lobe, Vane	1.50	2.00	1.25
Bottling Machinery	1.25	1.50	1.00	Extruders (metal)	2.00	2.50	1.50	Reciprocating—Sgl. or			
Brew Kettles (distilling) ..	1.25	1.50	1.00	Fans				Dbl. Acting Cylinder	2.00	2.50	2.00
Bucket Elevator or Conveyor	1.50	2.00	1.25	Centrifugal	1.25	1.50	1.00	Reel, Rewinder (paper)			
Calenders				Cooling Towers	2.00	2.50	1.50	Cable	1.50	2.00	1.25
Calender (paper)	1.50	2.00	1.25	Forced Draft, Large				Rod Mill	2.00	2.50	1.50
Calender (rubber),				Industrial	1.50	2.00	1.25	Saw Dust Conveyor	1.25	1.50	1.00
Calender-super (paper) ..	2.00	2.50	1.50	Feeders				Screens			
Cane Knives (sugar)	1.50	2.00	1.25	Apron, Belt, Disc	1.25	1.50	1.00	Air Washing, Water	1.25	1.50	1.00
Card Machine (textile) ..	2.00	2.50	1.50	Reciprocating	2.00	2.50	1.50	Rotary—Coal or Sand ..	1.50	2.00	1.25
Car Dumpers	2.00	2.50	1.50	Screw	1.50	2.00	1.25	Vibrating	2.00	2.50	2.00
Car Pullers	1.50	2.00	1.25	Filter, Press-Oil	1.50	2.00	1.25	Screw Conveyor	1.25	1.50	1.00
Cement Kiln	2.00	2.50	1.50	Generators				Slab Conveyor (lumber)	1.50	2.00	1.25
Centrifugal, Blower, Fans, Compressors, or Pumps	1.25	1.50	1.00	Uniform Load	1.25	1.50	1.00	Slitters (metal)	1.50	2.00	1.25
Chemical Feeders (sewage)	1.25	1.50	1.00	Varying Load, Hoist	1.50	2.00	1.25	Soapers (textile)	1.25	1.50	1.00
Chiller (oil)	1.50	2.00	1.25	Welders	2.00	2.50	1.50	Sorting Table (lumber) ..	1.50	2.00	1.25
Chipper (paper)	2.00	2.50	1.50	Grit Collector (sewage) ..	1.25	1.50	1.00	Spinner (textile)	1.50	2.00	1.25
Circular Resaw (lumber)	1.50	2.00	1.25	Grizzly	2.00	2.50	1.50	Stoker	1.25	1.50	1.00
Clarifier or Classifier	1.25	1.50	1.00	Hammermills				Suction Roll (paper)	1.50	2.00	1.25
Clay Working Machinery ..	1.50	2.00	1.25	Light Duty, Intermittent ..	1.50	2.00	1.25	Tenter Frames (textile) ..	1.50	2.00	1.25
Collectors (sewage)	1.25	1.50	1.00	Heavy Duty, Continuous ..	2.00	2.50	1.50	Tire Building Machines	2.00	2.50	1.50
Compressors				Hoists				Tire & Tube Press Opener	1.25	1.50	1.00
Centrifugal, Screw,				Heavy Duty	2.00	2.50	1.50	Tumbling Barrels	2.00	2.50	1.50
Lobe	1.25	1.50	1.00	Medium Duty	1.50	2.00	1.25	Washer & Thickener (paper)	1.50	2.00	1.25
Reciprocating		See Note		Jordan (paper)	2.00	2.50	1.50	Winches	1.50	2.00	1.25
Concrete Mixers	1.50	2.00	1.25	Kiln, Rotary	2.00	2.50	1.50	Winders—Paper, Textile, Wire	1.50	2.00	1.25
Converting Machine (paper) ..	1.50	2.00	1.25	Laundry Washer or Tumbler	2.00	2.50	1.50	Windlass	1.50	2.00	1.25
Conveyors				Line Shafts	1.25	1.50	1.00	Wire			
Apron, Assembly, Belt,				Log Hall (lumber)	2.00	2.50	1.50	Drawing	2.00	2.50	1.50
Flight, Oven, Screw	1.25	1.50	1.00	Loom (textile)	1.50	2.00	1.25	Winding	1.50	2.00	1.25
Bucket	1.50	2.00	1.25	Machine Tools,				Woodworking Machinery ..	1.25	1.50	1.00
Cookers—Brewing,				Main Drives	1.50	2.00	1.25				
Distilling, Food	1.25	1.50	1.00	Mangle (textile)	1.25	1.50	1.00				
Cooling Tower Fans	2.00	2.50	1.50	Mash Tubs (distilling) ..	1.25	1.50	1.00				
Couch (paper)	1.50	2.00	1.25	Meat Grinder	1.50	2.00	1.25				
Cranes & Hoists				Metal Forming							
Heavy duty mine	2.00	2.50	1.50	Machines	1.50	2.00	1.25				
Crushers—Cane (sugar), Stone, Ore	2.00	2.50	1.50	Mills							
Cutter-Paper	2.00	2.50	1.50	Ball, Pebble, Rod, Tube,							
Cylinder (paper)	2.00	2.50	1.50	Rubber, Tumbling	2.00	2.50	1.50				
Dewatering Screen (sewage)	1.50	2.00	1.25	Dryers, Coolers	1.50	2.00	1.25				
Disc Feeder	1.25	1.50	1.00	Mixers							
				Concrete, Muller	1.50	2.00	1.25				
				Banbury	2.00	2.50	1.50				
				Ore Crusher	2.00	2.50	1.50				
				Oven Conveyor	1.25	1.50	1.00				
				Planer (metal or wood) ..	1.50	2.00	1.25				
				Pressers							
				Brick, Briquette Machine ..	2.00	2.50	1.50				

SF

Caution: Applications involving reciprocating engines and reciprocating driven devices are subject to critical rotational speeds which may damage the coupling and/or connected equipment. Contact Lovejoy Engineering with specific requirements.

Sleeve Performance Data

Chart 2

Characteristics	Temperature Range	Misalignment Capabilities			Torsional Wind-Up
		Angular	Parallel	Axial	
EPDM—Unless otherwise specified, S-Flex couplings are supplied with EPDM flexible sleeves. EPDM has good resistance to commonly used chemicals and is generally not affected by dirt or moisture. Color is black.	-30° to +275° F -34° to +135° C	1°	up to .062	.125"	up to 15°
NEOPRENE ¹ —Neoprene provides very good performance characteristics for most applications and offers a very good resistance to chemical and oil conditions. Color is black with a green dot.	0° to +200° F -18° to +93° C	1°	up to .062	.125"	up to 15°
HYTREL ¹ —Hytrel is a polyester elastomer designed for high torque and high temperature applications and offers excellent resistance to chemical and oil conditions. Color is orange.	-65° to +250° F -54° to +121° C	.25°	up to .035	.125"	up to 7°

Note: 1. Neoprene and Hytrel are Registered Trademarks of E.I. DuPont Nemours & Co.

Coupling Nominal Rated Torque

Chart 3

Size	Min. Bore (in)	Max. Bore (in)	EPDM			Neoprene			Hytrel ¹		
			Torque		Max. RPM	Torque		Max. RPM	Torque		Max. RPM
			in-lb	Nm	in-lb	Nm	in-lb	Nm	in-lb	Nm	
3	.375	.875	60	6.78	9200	60	6.78	9200	N/A	N/A	N/A
4	.500	1.000	120	13.56	7600	120	13.56	7600	N/A	N/A	N/A
5	.500	1.188	240	27.12	7600	240	27.12	7600	N/A	N/A	N/A
6	.625	1.438	450	50.84	6000	450	50.84	6000	1800	203.37	6000
7	.625	1.625	725	81.91	5250	725	81.91	5250	2875	324.83	5250
8	.750	1.938	1135	128.24	4500	1135	128.24	4500	4530	511.82	4500
9	.875	2.375	1800	203.37	3750	1800	203.37	3750	7200	813.49	3750
10	1.125	2.750	2875	324.83	3600	2875	324.83	3600	11350	1282.38	3600
11	1.250	3.375	4530	511.82	3600	4530	511.82	3600	18000	2033.73	3600
12	1.500	3.875	7200	813.49	2800	7200	813.49	2800	31500	3559.03	2800
13	2.000	4.500	11350	1282.38	2400	11350	1282.38	2400	47268	5340.57	2400
14	2.000	5.000	18000	2033.73	2200	18000	2033.73	2200	72480	8189.15	2200
16	2.000	5.500	47250	5338.54	1500	N/A	N/A	N/A	N/A	N/A	N/A

Note: 1. Operating Hytrel within a high service factor application is not recommended.

S-Flex Standard Sleeve Chart

When referencing a Lovejoy Item (UPC) number, include 685144 as a prefix to the number shown in the table.

Sleeve Size	JE ¹		JES ¹		JN	JNS	E ¹		N	H	HS
	JE	Bulk Pack	JES	Bulk Pack			E	Bulk Pack			
3	36384	52712	36692	52713	35356	36866
4	35359	52714	36695	52715	35360	36869
5	35350	52716	36698	52717	35366	36872	35368	52718	35369
6	35569	52719	36701	52720	36394	36875	35600	52721	36411	40738	40741
7	35570	52722	36704	52723	36398	36878	36414	52724	36416	36848	41704
8	35572	52725	36707	52726	36402	36881	36419	52727	36421	36514	40072
9	36405	36864	36424	36426	40744	40747
10	35450	35451	36429	35453	35454	35455
11	36433	35457	35458	35459
12	36437	35461	35462	35463
13	35464	35465	35466
14	35467	35468	35469
16	35470

Note: 1. Bulk pack sizes 3-6 contain ten pieces, sizes 7-8 contain five pieces.

S-Flex Metric Bores Type J and S Flanges

Standard Bore and Keyway Chart

Bore (mm)	Keyway	3J	4J	5S	6S	7S	8S	9S	10S	11S	12S
9	No KW	41485
11	4 x 1.8	41486
12	No KW	41499
12	4 x 1.8	41487
14	No KW	41514
14	5 x 2.3	41488	41500	41515
15	No KW	41531
15	5 x 2.3	41489	41501
16	5 x 2.3	41490	41502	41516
19	No KW	41547
19	6 x 2.8	41491	41503	41517	41532	56571
20	6 x 2.8	41504	41518	41533
24	No KW	41561	41575
24	8 x 3.3	41505	41519	41534	51257	55746
25	8 x 3.3	41520	41535	41548
28	8 x 3.3	41521	41536	41549	41562
30	8 x 3.3	41537	41550	41563	41576	52258
32	10 x 3.3	41538	41551	41564	41577	59839
35	10 x 3.3	41539	49552	59721
38	10 x 3.3	55323	41552	41565	41578	45222	59889
42	12 x 3.3	41553	41566	41579	45883	59888
45	14 x 3.8	41567	46034	48389
48	14 x 3.8	41568	41580	59838	59887
50	14 x 3.8	44380	59855
52	16 x 4.3	58450	59720
55	16 x 4.3	45956	64136
60	18 x 4.4	52009	52711	54955
65	18 x 4.4	54941
70	20 x 4.9	59886	58725
80	22 x 5.4	59885	59856
90	25 x 5.4	59857

Note: 1. Metric Bore/Keyway per DIN specifications. See Engineering Section for Tolerances, (pg. ED-14).

SF

Type S Flanges-Inch Bore Chart

Standard Bore and Keyway Chart

When referencing a Lovejoy Item (UPC) number, include 685144 as a prefix to the number shown in the table.

Bore	Keyway	5S	6S	7S	8S	9S	10S	11S	12S	13S	14S	16S
1/2	No KW	36349
1/2	1/8 x 1/16	36067
5/8	No KW	36353	36355
5/8	3/16 x 3/32	36068	36093	36116
3/4	No KW	36357
3/4	3/16 x 3/32	36069	36094	36117	36132
13/16	3/16 x 3/32	36070
7/8	No KW	36359
7/8	3/16 x 3/32	36071	36095	36118	36133	36151
15/16	1/4 x 1/8	36072	36096	36119	36134	44363
1	1/4 x 1/8	36073	36097	36120	36135	36152
1 1/16	1/4 x 1/8	36074	36098	36121	44364	45742	46612
1 1/8	No KW	36361
1 1/8	1/4 x 1/8	36075	36099	36122	36136	36153	36363
1 3/16	1/4 x 1/8	36076	36100	36123	36137	46613
1 1/4	No KW	36365
1 1/4	1/4 x 1/16	36077
1 1/4	1/4 x 1/8	36101	36124	36138	36154	36171	36189
1 5/16	5/16 x 5/32	36102	36125	36139
1 3/8	5/16 x 5/32	36103	36126	36140	36155	36172	36190
1 7/16	3/8 x 3/16	36104	36127	36141	36156	36173
1 1/2	No KW	36367
1 1/2	3/8 x 1/8	36105
1 1/2	3/8 x 3/16	36128	36142	36157	36174	36191	36200
1 9/16	3/8 x 3/16	36158	36980	55291
1 5/8	3/8 x 1/8	36106
1 5/8	3/8 x 3/16	36129	36143	36159	36175	36192	55059
1 11/16	3/8 x 3/16	36144	36160	36176	49451
1 3/4	3/8 x 1/8	36107	36130
1 3/4	3/8 x 3/16	36145	36161	36177	36193	41773
1 7/8	1/2 x 1/8	36131
1 7/8	1/2 x 1/4	36146	36162	36178	36194	36201
1 15/16	1/2 x 1/4	36147	36163	36179	49816	56796
2 RSB	No KW	35441	35445	35448
2	1/2 x 1/4	36164	36180	45158	45672
2	1/2 x 3/16	36148
2 1/8	1/2 x 3/16	36149
2 1/8	1/2 x 1/4	36165	36181	36195	36202	55060	55062
2 3/16	1/2 x 1/4	36166	36182
2 1/4	1/2 x 1/4	36167	35183	45544	55560
2 3/8	5/8 x 1/8	36150
2 3/8	5/8 x 5/16	36168	36184	36196	36203	35442	55063
2 7/16	5/8 x 5/16	36185	55229	56808
2 1/2	5/8 x 3/16	36169
2 1/2	5/8 x 5/16	36186	56581	47895
2 3/4	5/8 x 5/16	46349	46585	45543	54940
2 7/8	3/4 x 1/8	36170	36187
2 7/8	3/4 x 3/8	36197	36204	35443	35446
3 3/8	7/8 x 3/16	36188
3 3/8	7/8 x 7/16	36198	36205	55061	55064
3 7/8	1 x 1/4	36199
3 7/8	1 x 1/2	36206

Notes: All standard finished bore keyway flanges have 2 set screws @ 90°. Sizes 13,14 and 16 RSB flanges are suitable for reboring and have two set screws @ 90°. Sizes 5-12 RSB flanges have no set screws.

Type J Flanges—Inch Bore Chart

When referencing a Lovejoy Item (UPC) number, include 685144 as a prefix to the number shown in the table.

Bore	Keyway	3J	4J	5J	6J
3/8	No KW	36046
1/2	No KW	36114	36115	36347
1/2	1/8 x 1/16	36047	36051	36057
5/8	No KW	36351
5/8	3/16 x 3/32	36048	36052	36058	36078
3/4	3/16 x 3/32	36049	36053	36059	36079
7/8	3/16 x 3/32	36050	36054	36060	36080
15/16	1/4 x 1/8	36055	36061	36081
1	1/4 x 1/8	36056	36062	36082
11/16	1/4 x 1/8	36063	36083
11/8	1/4 x 1/8	36064	36084
13/16	1/4 x 1/8	36085
11/4	1/4 x 1/8	36086
15/16	5/16 x 5/32	36087
13/8	5/16 x 5/32	36088

Standard Bore and Keyway Chart

Note:

1. We do not recommend reboring 3J or 4J Flanges.
2. See pg. ED-16 for standard keyway dimensions.



TYPE J

Type SC Spacer Flanges

Standard Availability Chart

For Required Shaft Separation ¹	SC Flange Size	Coupling Size														
		5	6	7	8	8-10	9	9-11	10	10-13	11	11-14	12	12-14	13	14
3 1/2	35	36524	36526	36532	36538	36540	36548
4 3/8	44	36528	36534	36542	36550
4 3/4	48	36560	36570
5	50	36530	36536	36544	36546	36552	36554	36562	36572
7	70	36556	36564	36574	36580	36582
7 3/4	78	36558	36566	36576	36584	36586	54200	54202
10	100	36568	36578	36588

Note: 1. See pg. SF-20 for other lengths possible thru various combinations.

H and HS Hubs (Hubs for Spacer Couplings)

Standard Bore and Keyway Chart

Bore	Keyway	5H	6H	7H	8H	9H	9HS	10H	10HS	11H	11HS	12H	12HS	13H	13HS	14H
1/2	No KW	36710
1/2	1/8 x 1/16	36711
5/8	No KW	36712	36714
5/8	3/16 x 3/32	36590	36713	36715
3/4	No KW	36718
3/4	3/16 x 3/32	36591	36600	36716	36719
7/8	No KW	36721	36910
7/8	3/16 x 3/32	36592	36601	36612	36624	36722
1	1/4 x 1/8	36593	36602	36613	36625	36640
11/8	No KW	36729	36912	36737	36914
11/8	1/4 x 1/8	36594	36603	36614	36626	36641	36682	36728	36684	36738	36686
11/4	1/4 x 1/8	36604	36717	36720	36723	36725	59905	36733	36741
13/8	5/16 x 5/32	36605	36615	36627	36642	36726	56486	36734	36742
11/2	3/8 x 3/16	36616	36628	36643	36727	59906	36735	59908	36743
15/8	3/8 x 3/16	36617	36629	36644	36656	36736	54909	36687
13/4	3/8 x 3/16	36630	36645	36730	59909
17/8	1/2 x 1/4	36631	36646	36657	36664	36745	36747
2	1/2 x 1/4	36724	36731	36739	36748
21/8	1/2 x 1/4	36647	36658	36665	36672	36749	36756
21/4	1/2 x 1/4	36732	36740	36746	36750
23/8	5/8 x 5/16	36659	36666	36673	36752	36757	36759
27/8	3/4 x 3/8	36667	36674	36753	36760
33/8	7/8 x 7/16	36754	36761
37/8	1 x 1/2	36762

S-Flex Coupling Ratings

S-Flex Coupling Ratings with EPDM, Neoprene or Hytrel

Coupling Size	Sleeve Material	Basic HP Ratings @Varying RPM				Torque Rating		Torsional ¹ Stiffness in-lb/rad	Max. Bore		Max. RPM
		100	1200	1800	3600	in-lbs	N-m		in	mm	
3	EPDM & Neoprene	.10	1.1	1.7	3.4	60	6.78	229	.875	22	9200
4	EPDM & Neoprene	.19	2.3	3.4	6.9	120	13.56	458	1.000	25	7600
5	EPDM & Neoprene	.38	4.6	6.9	13.7	240	27.12	916	1.188	30	7600
6	EPDM & Neoprene	.71	8.6	12.9	25.7	450	50.84	1718	1.438	38	6000
6H	Hytrel	2.90	34.0	51.0	103.0	1800	203.37	10000	1.438	38	6000
7	EPDM & Neoprene	1.20	14.0	21.0	41.0	725	81.91	2769	1.625	42	5250
7H	Hytrel	4.60	55.0	82.0	164.0	2875	324.83	20000	1.625	42	5250
8	EPDM & Neoprene	1.80	22.0	32.0	65.0	1135	128.24	4335	1.938	49	4500
8H	Hytrel	7.20	86.0	129.0	259.0	4530	511.82	30000	1.938	49	4500
9	EPDM & Neoprene	2.90	34.0	51.0	103.0	1800	203.37	6875	2.375	60	3750
9H	Hytrel	11.40	137.0	206.0	411.0	7200	813.49	47500	2.375	60	3750
10	EPDM & Neoprene	4.60	55.0	82.0	164.0	2875	324.83	10980	2.750	70	3600
10H	Hytrel	18.00	216.0	324.0	648.0	11350	1282.38	100000	2.750	70	3600
11	EPDM & Neoprene	7.20	86.0	129.0	259.0	4530	511.82	17300	3.375	86	3600
11H	Hytrel	28.60	343.0	514.0	1028.0	18000	2033.73	125000	3.375	86	3600
12	EPDM & Neoprene	11.40	137.0	206.0	7200	813.49	27500	3.875	99	2800
12H	Hytrel	50.00	600.0	900.0	31500	3559.03	225000	3.875	99	2800
13	EPDM & Neoprene	18.00	216.0	324.0	11350	1282.38	43350	4.500	114	2400
13H	Hytrel	75.00	900.0	1350.0	47268	5340.57	368900	4.500	114	2400
14	EPDM & Neoprene	28.60	343.0	514.0	18000	2033.73	68755	5.000	127	2200
14H	Hytrel	115.00	1380.0	2070.0	72480	8189.15	593250	5.000	127	2200
16	EPDM	75.00	900.0	47250	5338.54	180480	5.500	140	1500

- Notes:**
1. Values shown are for an ambient temperature of 75°F (24°C).
 2. Coupling ratings are based on sleeve material regardless of flange design.

Sleeves

S-Flex Sleeves

Flexible sleeves for Lovejoy S-Flex couplings are available in three materials (EPDM, Neoprene and Hytrel), and in three basic designs: one-piece solid, one-piece split, or two-piece.

Types JE, JN, JES, JNS

These sleeves feature a one-piece solid (JE, JN), as well as a one-piece split (JES, JNS) design. JE and JES are molded with EPDM rubber and JN and JNS are made with Neoprene in sizes 3–8. Sizes 9 and 10 are EPDM only.

Types E, N

Type E and N sleeves feature a two-piece design with retaining ring, available in either EPDM (E) or Neoprene (N). EPDM is available in sizes 5–16 and Neoprene is available in sizes 5–14. Two-piece sleeves are ideal for applications where small shaft separations inhibit the installation of a one-piece sleeve.

Types H, HS

Type H (Hytrel) sleeves, designed for high torque applications, transmit four times as much power as an equivalent EPDM or Neoprene sleeve. Available in one-piece solid (H) or two-piece split (HS) construction. Hytrel sleeves can be used only with S or SC flanges and cannot be used with J or B flanges. They should not be used as a direct replacement for EPDM or Neoprene applications. Hytrel is available for sizes 6–14. Size 13 and 14 Hytrel are available with HS sleeves only.

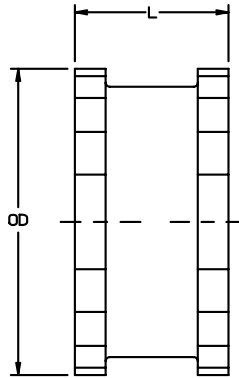

Types JE, JN, JES, JNS

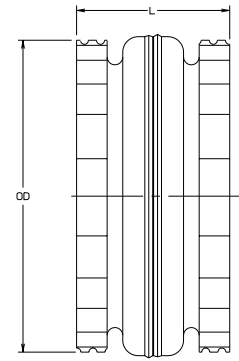

Types E, N

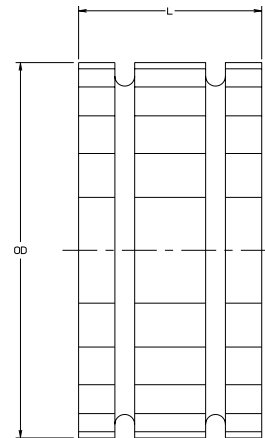

Types H, HS

Sleeve Dimensions—Inch

Coupling Size	Types JE, JES, JN & JNS EPDM & Neoprene			Types E & N EPDM & Neoprene			Types H & HS Hytrel		
	OD	L	Wt. lbs	OD	L	Wt. lbs	OD	L	Wt. lbs
3	1.88	1.00	0.06
4	2.31	1.25	0.10
5	2.94	1.56	0.20	2.94	1.56	0.25
6	3.75	1.88	0.40	3.75	1.88	0.49	3.75	1.88	0.44
7	4.34	2.19	0.62	4.34	2.19	0.77	4.34	2.19	0.69
8	5.06	2.50	1.13	5.06	2.50	1.40	5.06	2.50	1.40
9	6.00	3.00	1.46	6.00	3.00	2.00	6.00	3.00	1.80
10	7.06	3.44	2.32	7.06	3.44	3.20	7.06	3.44	2.90
11	8.19	4.00	5.10	8.19	4.00	4.50
12	9.56	4.69	8.10	9.56	4.69	7.30
13	11.19	5.50	13.00	11.19	5.50	11.80
14	13.09	6.50	21.10	13.09	6.50	19.30
16	17.91	8.75	45.30

Note: See page SF-10 for Performance Data.

SF

Type J Flanges and Type J Couplings

Type J Flanges

Type J flanges in sizes 3J and 4J are die cast of high-strength zinc alloy with a tensile strength of 41,000 psi and are furnished bored-to-size. Depending upon required bore size, the 5J is manufactured from either zinc alloy or cast iron. Size 6J is made of cast iron. J flanges can be used with either EPDM or Neoprene sleeves. Each flange has a keyseat and two set screws (one set screw over the key and one at 90° to the keyway).

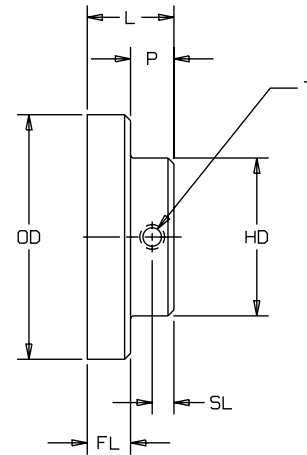

Type J Flange

Type J Couplings

Complete S-Flex couplings, with Type J flanges described above, are normally supplied with the one-piece JE sleeve or the one-piece split JES sleeve. They can also be supplied with the optional JN (Neoprene, one-piece) sleeve or the one-piece split JNS sleeve. Sizes 5J and 6J couplings are also available with E and N two-piece sleeves.

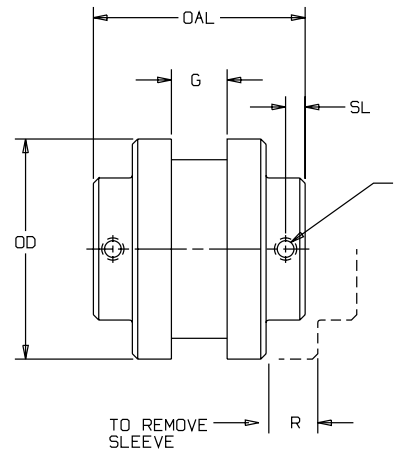

Type J Coupling

Type J Dimensional Data — Inch

Coupling Size	Max. Bore w/std. Keyway											Flange Wt. lbs	Complete Coupling Weight
		L	OD	P	G ¹	HD	OAL	FL	R	SL	T		
3J	0.875	0.81	2.062	0.44	0.38	1.50	2.00	0.38	0.56	.25	1/4-20	0.30	0.68
4J	1.000	0.88	2.460	0.44	0.63	1.63	2.38	0.44	0.75	.25	1/4-20	0.40	0.89
5J	1.125	1.06	3.250	0.47	0.75	1.88	2.88	0.59	0.97	.29	1/4-20	1.10	2.40
6J	1.375	1.31	4.000	0.53	0.88	2.50	3.50	0.78	1.09	.29	5/16-18	1.90	4.36

- Notes:
1. Spacing between shafts should be greater than 1/8" and less than OAL minus the sum of the two bore dimensions.
 2. See page SF-10 for Performance Data.

Type S Flanges and Type S Couplings

Type S Flanges

Model S flanges are made of high-strength cast iron and are bored-to-size for a slip fit on standard shafts. They are easy to install and remove, and are readily available from stock in a wide range of popular bore sizes.

Type S Couplings

Type S couplings, normally supplied with the two-piece E sleeve, can be used with any JE, JN, N, H, or HS sleeve.

Type S flanges will be furnished standard with two set screws at 90°.

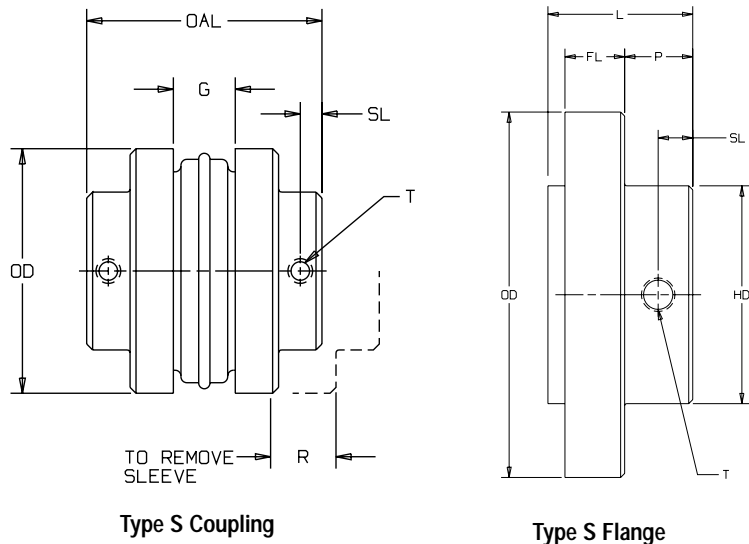

SF

Type S Dimensional Data—Inch

Coupling Size	Max. Bore		L	OD	P	G ¹	HD	OAL	FL	R	T	SL	Flange Wt. lbs
	Std. Keyway	Shallow Keyway											
5S	1.188	1.250	1.34	3.250	0.45	0.75	1.88	2.81	0.59	0.97	.25-20	0.29	1.1
6S	1.438	1.500	1.64	4.000	0.53	0.88	2.50	3.50	0.78	1.09	.31-18	0.29	1.9
		1.750	1.64	4.000	0.53	0.88	2.50	3.50	0.78	1.09	1.8
7S	1.625	1.875	1.84	4.625	0.69	1.00	2.81	3.94	0.78	1.31	.38-16	0.35	2.6
8S	1.938	2.250	2.10	5.450	0.75	1.13	3.25	4.39	0.88	1.50	.38-16	0.38	4.4
		2.375	1.94	5.450	1.03	1.13	3.25	4.95	0.88	1.50	3.7
9S	2.375	2.500	2.41	6.350	0.78	1.44	3.63	5.06	1.03	1.75	.5-13	0.41	6.5
		2.875	2.28	6.350	1.25	1.44	4.13	6.00	1.03	1.75	6.2
10S	2.750	3.125	2.70	7.500	0.81	1.63	4.38	5.69	1.22	2.00	.5-13	0.41	10.5
		3.375	2.70	7.500	0.81	1.63	4.75	5.69	1.22	2.00	9.8
11S	3.375	3.625	3.44	8.625	1.13	1.88	5.25	7.13	1.50	2.38	.5-13	0.56	16.6
		3.875	3.06	8.625	1.56	1.88	5.63	8.00	1.50	2.38	16.4
12S	2.875	4.00	10.000	1.28	2.31	4.88	8.25	1.69	2.69	.5-13	0.63	27.5
		3.875	4.00	10.000	1.28	2.31	5.75	8.25	1.69	2.69	26.6
13S	4.500	4.38	11.750	1.31	2.69	6.75	9.25	1.97	3.06	.63-11	0.81	45.0
14S	5.000	4.50	13.875	1.06	3.25	7.50	9.88	2.25	3.50	.63-11	0.62	69.0
16S	5.500	6.000	6.00	18.875	2.00	4.75	8.00	14.50	2.75	4.25	.63-11	1.00	125.0

- Notes:**
1. Spacing between shafts should be greater than 1/8" and less than OAL minus the sum of the two bore dimensions.
 2. See page SF-10 for Performance Data.

S Flanges and Couplings



TYPE S COUPLING



TYPE S COUPLING WITH E SLEEVE

Shallow Keyway Dimensional Data—Inch

Coupling Size	L	HD	Max Bore		Shallow Keyway Dimensions								
			Std Keyway	Shallow Keyway	Bore	Keyway	Key	Bore	Keyway	Key	Bore	Keyway	Key
5S	1.34	1.88	1.188	1.250	1.25	.25 x .06	.25 x .19 x 1.38
6S	1.63	2.50	1.438	1.500	1.50	.38 x .13	.38 x .31 x 1.5
	1.31	2.50	1.750	1.56 - 1.63	.38 x .13	.38 x .31 x 1.31	1.69 - 1.75	.38 x .06	.38 x .25 x 1.25
7S	1.84	2.81	1.625	1.875	1.69 - 1.75	.38 x .13	.38 x .31 x 1.81	1.81 - 1.88	.5 x .13	.5 x .38 x 1.81
8S	2.09	3.25	1.938	2.250	2 - 2.25	.5 x .19	.5 x .44 x 2.06
9S	1.94	3.25	2.375	2.31 - 2.38	.63 x .13	.63 x .44 x 1.88
	2.41	3.63	2.375	2.500	2.44 - 2.5	.63 x .19	.63 x .5 x 2.38
10S	2.28	4.13	2.875	2.56 - 2.75	.63 x .19	.63 x .5 x 2.25	2.81 - 2.88	.75 x .13	.75 x .5 x 2.25
	2.72	4.38	2.750	3.125	2.81 - 3.13	.75 x .13	.75 x .5 x 2.75
11S	2.69	4.75	3.375	3.18 - 3.25	.38 x .25	.75 x .5 x 2.63	3.31 - 3.38	.88 x .19	.88 x .63 x 2.63
	3.44	5.25	3.375	3.625	3.44 - 3.63	.88 x .19	.88 x .63 x 3.44
12S	3.06	5.63	3.875	3.69 - 3.75	.88 x .19	.88 x .63 x .3	3.88	1 x .25	1 x .75 x 3
	4.00	4.88	2.875
13S	4.00	5.75	3.875	3.938	3.94	1 x .13	1 x .63 x 4
	4.38	6.75	4.500
14S	4.50	7.50	5.000
16S	6.00	8.00	5.500	6.000	5.56 - 6	1.5 x .25	1.5 x 1 x 6

- Notes:**
1. Some large bore Type S flanges are supplied with shallow keyways as standard. Rectangular keystock is provided for stock bores only.
 2. See page SF-10 for Performance Data.

Type B Flanges For Use With QD® Bushings

Type B Flanges

Model B (bushed) flanges are made of the same high-strength cast iron as the S flanges. B flanges, however, are designed to accommodate the industry standard QD bushing for easy installation and removal. B flanges are available in sizes 6 thru 16.

Couplings

S-Flex couplings with B flanges (for use with QD bushings) are normally supplied with the two-piece E sleeve. S-Flex B flange couplings can be supplied with any of the sleeves shown on page SF-7 with the exception of Hytrel. It is permissible to combine B flanges with S flanges.

Bushings

QD® Bushings with their split design allow a compression fit for secure mounting of the flange to the shaft without set screws. This clamp-like fit creates a one-piece assembly to eliminate wobble, vibration, and fretting corrosion. Slightly oversized or undersized shafts can be accommodated with the same secure grip. The QD design prevents potentially hazardous keydrift on applications subject to pulsation or vibration. Model B flanges bored for QD bushing accommodate many bore sizes, thus reducing inventory and increasing coupling versatility. QD bushing bore availability can be found in current Lovejoy List Price books or from your Customer Service Representative.

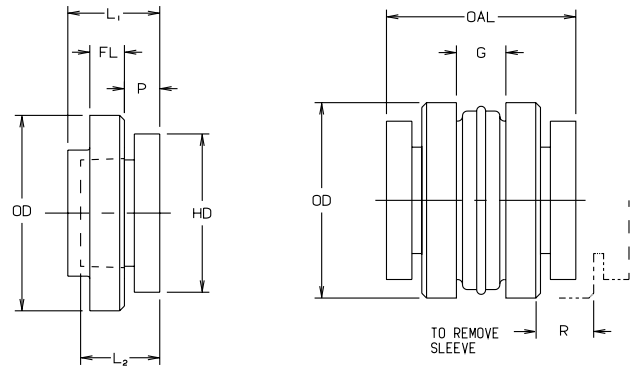

Type B Flange

Type B Coupling

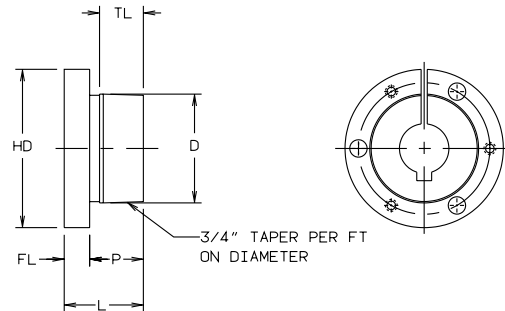

QD Bushing

B Flange and Coupling Dimensional Data—Inch

Flange Item No.	Coupling Size	Bushing Required	L ₁	L ₂	OD	P	HD	G ¹	OAL	FL	Max R	Approx. Bore	Flange Wt. lbs
36369	6B	JA	1.53	1.00	4.000	0.44	2.00	0.88	3.31	0.78	1.09	1.19	1.3
36371	7B	JA	1.59	1.00	4.625	0.44	2.00	1.00	3.44	0.78	1.31	1.19	1.9
36373	8B	SH	1.84	1.25	5.450	0.50	2.69	1.13	3.94	0.91	1.50	1.63	2.9
36375	9B	SD	2.19	1.81	6.350	0.56	3.19	1.44	4.63	1.03	1.75	1.94	4.8
35421	10B	SK	1.84	1.88	7.500	0.63	3.88	1.63	5.31	1.22	2.00	2.50	7.8
35432	11B	SF	2.13	2.00	8.625	0.63	4.63	1.88	6.13	1.50	2.38	2.75	12.0
36408	12B	E	2.69	2.63	10.000	0.88	6.00	2.31	7.44	1.69	2.69	3.44	18.0
35444	13B	F	3.69	3.63	11.750	1.00	6.63	2.69	8.63	1.97	3.00	3.94	31.2
35447	14B	F	3.69	3.63	13.875	1.00	6.63	3.25	9.75	2.25	3.50	3.94	51.4
35449	16B	J	4.75	4.50	18.875	1.19	7.25	4.75	12.63	2.75	4.25	4.50	120.0

Note: 1. Spacing between shafts should be greater than 1/8" and less than G. Spacing between internal face of flange should be OAL—(2 x L₁).

QD® Bushing Dimensional Data—Inch

Bushing Size	HD	FL	D	P	TL	L	Min. Bore	Max. Bore		Number & Size of Cap Screws Req.	Cap Screw Torque ft-lb	Wt. lbs
								Std. Keyway	Shallow Keyway ²			
JA	2.00	0.31	1.375	0.69	0.56	1.00	0.50	1.00	1.19	3- #10-1	5	0.8
SH	2.68	0.38	1.871	0.88	0.81	1.25	0.50	1.38	1.63	3- .25 - 1.38	9	0.9
SD	3.18	0.44	2.187	1.38	1.25	1.81	0.50	1.63	1.94	3- .25 - 1.8	9	1.6
SK	3.88	0.50	2.812	1.38	1.25	1.87	0.50	2.13	2.50	3- .31 - 2	15	2.8
SF	4.63	0.50	3.125	1.50	1.25	2.00	0.50	2.31	2.81	3- .38 - 2	30	3.9
E	6.00	0.75	3.834	1.88	1.63	2.62	0.88	2.88	3.50	3- .5 - 2.75	60	8.5
F	6.63	0.81	4.438	2.81	2.50	3.63	1.00	3.25	3.94	3- .56 - 3.63	75	13.9
J	7.25	1.00	5.148	3.50	3.19	4.50	1.44	3.75	4.50	3- .63 - 4.5	135	21.6

- Notes:
1. F and J bushings are not available from Lovejoy. F bushings are available commercially in a bore range of 1" to 4", J bushings in a range of 1 7/16" to 4 1/2".
 2. Rectangular keys are furnished at no charge when shallow keyway is necessary.
 3. QD is a registered trademark of Emerson Electric Corp.
 4. See page SF-10 for Performance Data.

Type T Flange For Use With Taper-Lock® Bushings

Type TF Flanges

Model TF (bushed) flanges are made of the same high-strength cast iron as the S flanges, but are designed to accommodate the international standard Taper-Lock® bushing for easy installation and removal. The TF type flange allows for mounting the bushing on the front (hub) side of the flange. TF flanges are available in sizes 6 thru 16 and can be used with any style of sleeve as shown on page SF-7.

Type TR Flanges

Model TR flanges are the same as TF with the exception that the bushing is mounted and removed from the reverse or serration side of the flange. Due to the limited torque ratings of the bushings, TR flanges can only be used with EPDM or Neoprene sleeves. Different bushing sizes are used, so they have different maximum bores than the TF flanges. Sizes 6 through 16 are available.

Taper-Lock® Bushings

An industry standard, the split design allows a compression fit of the flange to the shaft without set screws. The simple design makes installation and removal easy, while the 8° taper grips tight and provides excellent concentricity. Since many other power transmission components use Taper-Lock® such as sheaves, sprockets, and pulleys, the versatility and reduced inventory are key benefits. Lovejoy does not offer the Taper-Lock® Bushings themselves as these are widely available from other manufacturers.

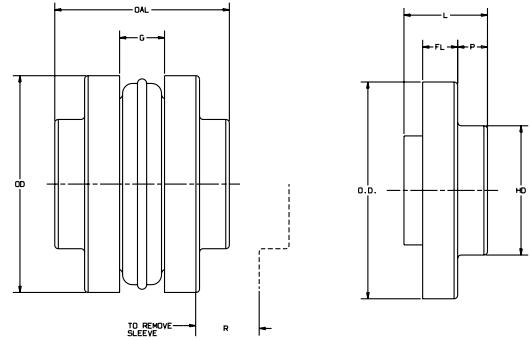

Note: Be sure to determine if the bushing being used has either UNC threads (60°) or British Standard Whitworth B.S.W. threads (55°). In the U.S.A. the UNC type is predominant for both inch and metric bores. Outside of the U.S.A. it is most common to see B.S.W., especially on metric bores.

S-Flex Taper Dimensional Data (Front Mount)—Inch

UNC Flange Item (UPC) No.	BSW Flange Item (UPC) No.	Coupling Size	Max. Bore		L	OD	P	G	HD	OAL	FL	R	Bushing Screw Size	Flange Wt. lbs	Bushing Required*
			in	mm											
62265	62263	6TF	1.25	31	1.56	4.00	0.78	0.88	2.81	4.00	0.78	1.09	3/8-16	1.8	1215/1210
62269	62267	7TF	1.25	31	1.84	4.62	0.69	1.00	2.81	3.94	0.78	1.31	3/8-16	2.6	1215/1210
62273	62271	8TF	1.62	42	1.94	5.45	1.03	1.13	3.25	5.00	0.91	1.50	3/8-16	3.7	1615/1610
62277	62275	9TF	2.00	50	2.28	6.35	1.25	1.44	4.13	6.00	1.03	1.75	7/16-14	6.2	2012
62281	62279	10TF	2.50	64	2.69	7.50	1.47	1.63	4.75	7.00	1.22	2.00	1/2-13	9.8	2517
62285	62283	11TF	2.50	64	3.06	8.63	1.56	1.88	5.63	8.00	1.50	2.38	1/2-13	16.4	2517
62289	62287	12TF	3.00	76	4.00	10.00	1.28	2.31	5.75	8.25	1.69	2.69	5/8-11	26.6	3030
62293	62294	13TF	3.00	76	4.38	11.75	1.31	2.69	6.75	9.25	1.97	3.06	5/8-11	45.0	3030
62297	62295	14TF	3.94	100	4.50	13.88	1.06	3.25	7.50	9.88	2.25	3.50	1/2-13	69.0	3535
62301	62299	16TF	4.44	112	6.00	18.88	2.00	4.75	8.00	14.50	2.75	4.25	5/8-11	125.0	4040

S-Flex Taper Dimensional Data (Rear Mount)—Inch

UNC Flange Item (UPC) No.	BSW Flange Item (UPC) No.	Coupling Size	Max. Bore		L	OD	P	G	HD	OAL	FL	R	Bushing Screw Size	Flange Wt. lbs	Bushing Required*
			in	mm											
62266	62264	6TR	1.00	25	1.56	4.00	0.78	0.88	2.81	4.00	0.78	1.09	1/4-20	1.8	1008
62270	62268	7TR	1.12	28	1.84	4.62	0.69	1.00	2.81	3.94	0.78	1.31	1/4-20	2.6	1108
62274	62272	8TR	1.25	31	1.94	5.45	1.03	1.13	3.25	5.00	0.91	1.50	3/8-16	3.7	1215/1210
62278	62276	9TR	1.62	42	2.28	6.35	1.25	1.44	4.13	6.00	1.03	1.75	3/8-16	6.2	1615/1610
62282	62280	10TR	1.62	42	2.69	7.50	1.47	1.63	4.75	7.00	1.22	2.00	3/8-16	9.8	1615/1610
62286	62284	11TR	2.50	64	3.06	8.63	1.56	1.88	5.63	8.00	1.50	2.38	1/2-13	16.4	2525
62290	62288	12TR	2.50	64	4.00	10.00	1.28	2.31	5.75	8.25	1.69	2.69	1/2-13	26.6	2517
62294	62292	13TR	3.00	76	4.38	11.75	1.31	2.69	6.75	9.25	1.97	3.06	5/8-11	45.0	3030
62298	62296	14TR	3.00	76	4.50	13.88	1.06	3.25	7.50	9.88	2.25	3.50	5/8-11	69.0	3030
62302	62300	16TR	4.44	112	6.00	18.88	2.00	4.75	8.00	14.50	2.75	4.25	5/8-11	125.0	4040

- Notes:**
1. All above data refers to both standard UNC and British Standard Whitworth B.S.W. threads. Flanges are not supplied with screws.
 2. * indicates that use of a 1210 or 1610 bushing reduces the reserve factor between bushing torque rating and that of the coupling.
 3. Taper-Lock® is a registered trademark of Reliance Electric Industrial Company in the United States and Canada. It is a registered trademark of JH Fenner and Co. in the United Kingdom.

SF-16 4. See page SF-10 for Performance Data.

Type SC Spacer Couplings

Specially designed for the pump industry, this coupling accommodates industry standard as well as special pump/motor shaft separation. This shaft separation facilitates easy repair of pump packing, bearings and seals without disturbing pump or motor mounting and alignment. The SC coupling consists of two flanges, a sleeve and two shaft hubs.

Quick Coupling Removal

The center drop out section consists of two flanges and the flexible sleeve. The flange is bolted to the shaft hub with four hex head cap screws. By simply removing these screws, the center section can be removed. Flats on each hub provide convenient grip for a wrench in order to facilitate loosening of the screws and, if desired, turning of the pump/motor shafts. Once the hub is removed from the pump shaft, maintenance on the pump can be done without disturbing equipment alignment.

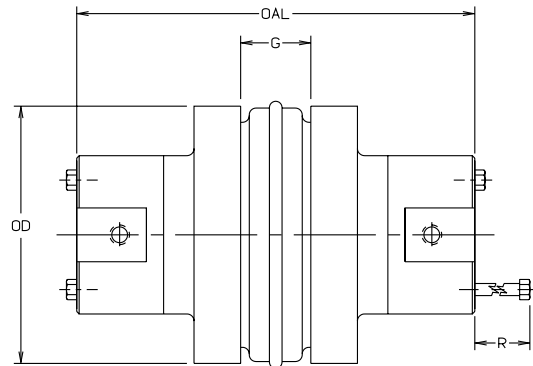

SC (Spacer) Coupling Dimensional Data—Inch

Coupling Size	For Required Shaft Separation	Use Flange No.	Use Hub No.	OD	OAL ²	G	R	Complete Coupling ² Weight lbs
5SC	3.50	5SC35	5SCH	3.250	5.63	0.75	0.56	4.5
6SC	3.50	6SC35	6SCH	4.000	5.88	0.88	0.75	7.3
	4.38	6SC44	6SCH	4.000	6.75	0.88	0.75	8.1
	5.00	6SC50	6SCH	4.000	7.38	0.88	0.75	8.7
7SC	3.50	7SC35	7SCH	4.625	6.38	1.00	0.63	9.9
	4.38	7SC44	7SCH	4.625	7.25	1.00	0.63	10.8
	5.00	7SC50	7SCH	4.625	7.88	1.00	0.63	11.4
8SC	3.50	8SC35	8SCH	5.450	6.88	1.13	0.81	15.2
	3.50	8SC35-10	10SCH ¹	5.450	8.13	1.13	0.81	23.2
	4.38	8SC44	8SCH	5.450	7.75	1.13	0.81	16.4
	5.00	8SC50	8SCH	5.450	8.38	1.13	0.81	17.4
9SC	5.00	8SC50-10	10SCH ¹	5.450	9.63	1.13	1.19	27.2
	3.50	9SC35	9SCH ¹	6.350	7.50	1.44	1.06	18.6
	4.38	9SC44	9SCH ¹	6.350	8.25	1.44	1.06	22.2
	5.00	9SC50	9SCH ¹	6.350	8.88	1.44	1.06	23.2
10SC	5.00	9SC50-11	11SCH ¹	6.350	10.38	1.44	1.19	40.4
	7.00	9SC70-11	11SCH ¹	6.350	12.38	1.44	1.19	48.2
	7.75	9SC78-11	11SCH ¹	6.350	13.13	1.44	1.19	51.0
	4.75	10SC48	10SCH ¹	7.500	9.38	1.63	1.19	37.6
11SC	5.00	10SC50	10SCH ¹	7.500	9.63	1.63	1.19	38.4
	7.00	10SC70-13	13SCH ¹	7.500	13.63	1.63	1.88	72.0
	7.75	10SC78-13	13SCH ¹	7.500	14.38	1.63	1.88	76.0
	10.00	10SC100-13	13SCH ¹	7.500	16.63	1.63	1.88	88.0
12SC	4.75	11SC48	11SCH ¹	8.625	10.31	1.88	1.19	54.5
	5.00	11SC50	11SCH ¹	8.625	10.38	1.88	1.19	54.7
	7.00	11SC70-14	14SCH	8.625	14.63	1.88	2.00	86.1
	7.75	11SC78-14	14SCH	8.625	15.38	1.88	2.00	90.3
13SC	10.00	11SC100-14	14SCH	8.625	17.63	1.88	2.00	102.7
	7.00	12SC70	12SCH ¹	10.000	12.88	2.31	1.50	88.1
	7.00	12SC70-14	14SCH	10.000	14.63	2.31	2.00	99.1
	7.75	12SC78	12SCH ¹	10.000	13.63	2.31	1.50	91.9
14SC	7.75	12SC78-14	14SCH	10.000	15.38	2.31	2.00	103.3
	7.75	13SC78	13SCH ¹	11.750	14.38	2.69	1.88	129.6
14SC	7.75	14SC78	14SCH	13.875	15.38	3.25	2.00	179.9

- Notes:**
1. SC Hubs are available in: SC= Standard Length SCHS= Short Length
 2. OAL dimension and weight will vary if one or two short (HS) hubs are used.
 3. See page SF-10 for Performance Data.

Type SC (Spacer)

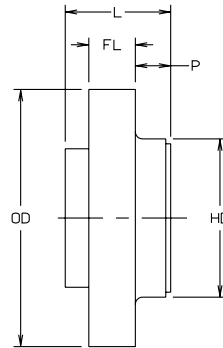

SC Flange Dimensional Data—Inch

Coupling Size	Flange No.	For Required Shaft Separation ¹	SC Hub No.	OD	P	HD	L	FL	Flange Wt. lbs (Each flange)
5SC	5SC35	3.50	5SCH	3.250	0.80	2.00	1.69	0.59	1.3
6SC	6SC35	3.50	6SCH	4.000	0.59	2.50	1.63	0.72	2.0
	6SC44	4.38	6SCH	4.000	1.03	2.50	2.06	0.72	2.4
	6SC50	5.00	6SCH	4.000	1.34	2.50	2.38	0.72	2.7
7SC	7SC35	3.50	7SCH	4.625	0.47	2.81	1.63	0.78	2.5
	7SC44	4.38	7SCH	4.625	0.91	2.81	2.06	0.78	3.0
	7SC50	5.00	7SCH	4.625	1.22	2.81	2.38	0.78	3.3
8SC	8SC35	3.50	8SCH	5.450	0.28	3.25	1.63	0.91	3.7
	8SC35-10	3.50	10SCH(HS)	5.450	0.28	4.38	1.63	0.91	3.5
	8SC44	4.38	8SCH	5.450	0.72	3.25	2.06	0.91	4.3
	8SC50	5.00	8SCH	5.450	1.03	3.25	2.38	0.91	4.8
	8SC50-10	5.00	10SCH(HS)	5.450	1.03	4.38	2.38	0.91	5.5
9SC	9SC35	3.50	9SCH(HS)	6.350	0.06	3.63	1.69	1.03	4.1
	9SC44	4.38	9SCH(HS)	6.350	0.44	3.63	2.06	1.03	5.9
	9SC50	5.00	9SCH(HS)	6.350	0.75	3.63	2.38	1.03	6.4
	9SC50-11	5.00	11SCH(HS)	6.350	0.75	5.25	2.38	1.03	7.0
	9SC70-11	7.00	11SCH(HS)	6.350	1.75	5.25	3.38	1.03	10.9
	9SC78-11	7.75	11SCH(HS)	6.350	2.13	5.25	3.75	1.03	12.3
10SC	10SC48	4.75	10SCH(HS)	7.500	0.34	4.38	2.25	1.22	9.8
	10SC50	5.00	10SCH(HS)	7.500	0.47	4.38	2.38	1.22	10.2
	10SC70-13	7.00	13SCH(HS)	7.500	1.47	6.13	3.38	1.22	14.5
	10SC78-13	7.75	13SCH(HS)	7.500	1.84	6.13	3.75	1.22	16.5
	10SC100-13	10.00	13SCH(HS)	7.500	2.97	6.13	4.88	1.22	22.5
11SC	11SC48	4.75	11SCH(HS)	8.625	0.03	5.25	1.50	1.50	12.5
	11SC50	5.00	11SCH(HS)	8.625	0.06	5.25	1.56	1.50	12.6
	11SC70-14	7.00	14SCH	8.625	1.06	6.50	2.56	1.50	16.3
	11SC78-14	7.75	14SCH	8.625	1.44	6.50	2.94	1.50	18.4
	11SC100-14	10.00	14SCH	8.625	2.56	6.50	4.06	1.50	24.6
12SC	12SC70	7.00	12SCH(HS)	10.000	0.66	5.75	2.47	1.69	23.4
	12SC70-14	7.00	14SCH	10.000	0.66	6.50	2.47	1.69	21.3
	12SC78	7.75	12SCH(HS)	10.000	1.03	5.75	2.84	1.69	25.3
	12SC78-14	7.75	14SCH	10.000	1.03	6.50	2.84	1.69	23.4
	12SC100-14	10.00	14SCH	10.000	2.16	6.50	3.97	1.69	29.6
13SC	13SC78	7.75	13SCH(HS)	11.750	0.56	6.13	3.25	1.97	38.4
14SC	14SC78	7.75	14SCH	13.875	0.03	6.50	2.72	2.25	55.2

- Notes:**
1. Flanges can be mixed to form different shaft separations.
 2. Metric Flanges and hubs are also available. Consult Lovejoy Engineering for specific information.
 3. See page SF-10 for Performance Data.

Type SC (Spacer)

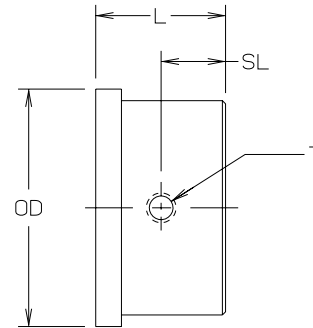

SF

SC Hub Dimensional Data—Inch

Coupling Size	Hub No. ¹	Max. Bore Std Kw	L	OD	Capscrews	SL	T	Hub Wt. lbs
5SC	5SCH	1.125	1.09	2.00	4-#10 x 1.5	0.54	.31-18	0.8
6SC	6SCH	1.375	1.22	2.50	4-.25 x 1.75	0.61	.31-18	1.4
7SC	7SCH	1.625	1.47	2.81	4-.25 x 1.88	0.71	.31-18	2.0
8SC	8SCH	1.875	1.72	3.25	4-.31 x 2.25	0.66	.38-16	3.2
	10SCH	2.375	2.34	4.38	4-.44 x 3.25	0.63	.5-13	7.4
	10SCHS	1.625	1.66	4.38	4-.44 x 2.5	0.63	.5-13	5.5
9SC	9SCH	2.125	1.97	3.63	4-.38 x 2.75	1.17	.38-16	4.2
	9SCHS	1.500	1.53	3.63	4-.38 x 2.25	0.63	.38-16	3.7
	11SCH	2.875	2.72	5.25	4-.5 x 3.5	1.36	.5-13	12.2
	11SCHS	1.875	1.91	5.25	4-.5 x 2.75	0.75	.5-13	9.3
10SC	10SCH	2.375	2.34	4.38	4-.44 x 3.25	1.17	.5-13	7.4
	10SCHS	1.625	1.66	4.38	4-.44 x 2.5	0.63	.5-13	5.5
	13SCH	3.375	3.34	6.13	4-.63 x 4.75	1.65	.75-10	19.9
	13SCHS	2.500	2.47	6.13	4-.63 x 3.5	1.24	.75-10	16.0
11SC	11SCH	2.875	2.72	5.25	4-.5 x 3.5	1.36	.5-13	12.2
	11SCHS	1.875	1.91	5.25	4-.5 x 2.75	0.75	.5-13	9.3
	14SCH	3.875	3.84	6.50	4-.63 x 5	1.92	.75-10	24.2
12SC	12SCH	2.875	2.97	5.75	4-.63 x 4	1.44	.63-11	16.6
	12SCHS	2.500	2.53	5.75	4-.63 x 3.5	1.12	.63-11	14.1
	14SCH	3.875	3.84	6.50	4-.63 x 5	1.92	.75-10	24.2
13SC	13SCH	3.375	3.34	6.13	4-.63 x 4.75	1.65	.75-10	19.9
	13SCHS	2.500	2.47	6.13	4-.63 x 3.5	1.24	.75-10	16.0
14SC	14SCH	3.875	3.38	6.50	4-.63 x 5	1.92	.75-10	24.2

Notes: 1. SCH = Standard length SCHS = Short length
 2. See page SF-10 for Performance Data.

Type SC (Spacer)

Shaft Separation Distances

SC (Spacer) type couplings are available with the most popular shaft separation distances. Other separations can be achieved by combining different spacer flanges. The "standard" column illustrates separations available using identical flanges. The "combination" column illustrates combined flanges of different separations, and the "semi-spacer" column illustrates combinations of SC (Spacer) flanges and standard S flanges.



SF

STANDARD

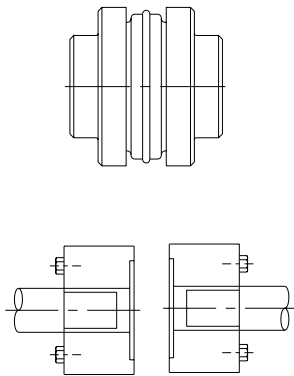

COMBINATION

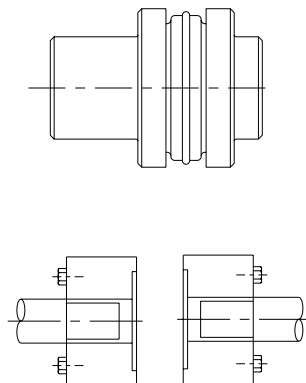

SEMI-SPACER

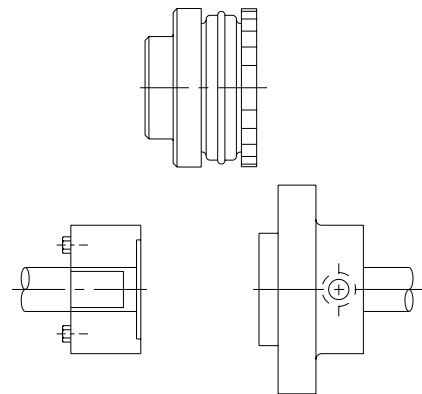

Combination

Spacing	Use Flanges ¹
$3\frac{15}{16}$	SC35 & SC44
$4\frac{1}{4}$	SC44 & SC50
$5\frac{1}{4}$	SC35 & SC70
$5\frac{5}{8}$	SC35 & SC78
$5\frac{11}{16}$	SC44 & SC70
6	SC50 & SC70
$6\frac{1}{16}$	SC44 & SC78
$6\frac{3}{8}$	SC50 & SC78
$6\frac{3}{4}$	SC35 & SC100 ²
$7\frac{3}{16}$	SC44 & SC100 ²
$7\frac{3}{8}$	SC70 & SC78
$7\frac{1}{2}$	SC50 & SC100
$8\frac{1}{2}$	SC70 & SC100
$8\frac{7}{8}$	SC78 & SC100

Standard

Spacing	Use Flanges
$3\frac{1}{2}$	2-()SC35
$4\frac{3}{8}$	2-()SC44
5	2-()SC50
7	2-()SC70
$7\frac{3}{4}$	2-()SC78
10	2-()SC100

Semi-Spacer

Spacing	Use Flanges ¹
$1\frac{7}{8}$	S & SC35
$2\frac{5}{16}$	S & SC44
$2\frac{5}{8}$	S & SC50
$3\frac{5}{8}$	S & SC70
4	S & SC78
$5\frac{1}{8}$	S & SC100

- Notes:**
1. Check for flange availability of coupling size.
 2. Non stock.
 3. See page SF-10 for Performance Data.